



Samsung Electronics Co.,Ltd.
Printed in Korea
06/2001 Rev 1.0
GH68-02098A

SAMSUNG

DUAL BAND Mobile Cellular Phone SGH-R200

SERVICE Manual

DUAL BAND MOBILE CELLULAR PHONE



CONTENTS

1. Exploded Views and Parts List
2. PCB Diagrams
3. Electrical Parts List
4. Block Diagrams
5. Flow Chart of Troubleshooting

1. Exploded Views and Parts List

- 1-1 Main
- 1-2 Main Parts List
- 1-3 Travel Adapter
- 1-4 Travel Adapter Parts List
- 1-5 Ciger Light Adapter
- 1-6 Ciger Light Adapter Parts List
- 1-7 Test Jig
- 1-8 EAR Microphone
- 1-9 Data Kit

2. PCB Diagrams

- 2-1 Main Top
- 2-2 Main Bottom

3. Electrical Parts List

- 3-1 Main Parts List Top
- 3-2 Main Parts List Bottom

4. Block Diagrams

- 4-1 Main Baseband
- 4-2 Main RF
 - 4-2-1 RF Transmit Part
 - 4-2-2 RF Receive Part

5. Flow Chart of Troubleshooting and Circuit Diagrams

- 5-1 Power ON
 - 5-2 Initial
 - 5-3 Charging Part
 - 5-4 Sim Part
 - 5-5 Microphone Part
 - 5-6 Speaker Part
 - 5-7 Key Data Input
 - 5-8 Alert Tone
 - 5-9 Ring Indicator
 - 5-10 Back Light
 - 5-11 GSM Receiver
 - 5-12 GSM Transmitter
 - 5-13 DCS Receiver
 - 5-14 DCS Transmitter
-

1. Exploded Views and Parts List

1-1 Main

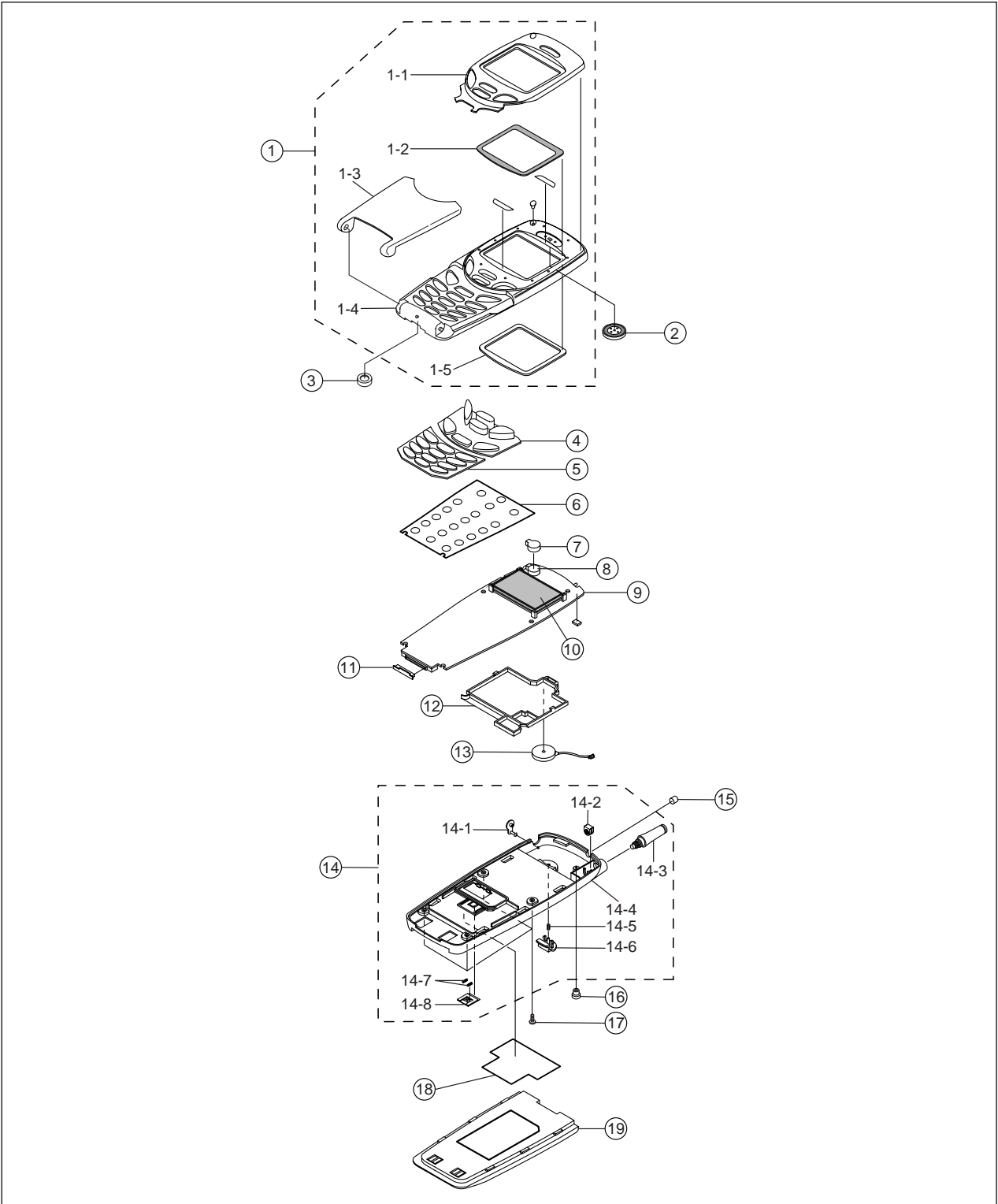

1-2 Main Parts List

NO	PARTS NAME	SEC CODE			Q'TY	SVC	REMARK	
		BLUE	GREEN	D/GRAY				
1	1	FRONT COVER ASS'Y	GH75-01302A	GH75-01303A	GH75-01304A	1	SA	
	1-1	DUMMY-FRONT	GH72-02547A	GH72-02547A	GH72-02547A	1	SNA	
	1-2	WINDOW LCD	GH72-02549A	GH72-02549A	GH72-02549A	1	SNA	
	1-3	FLIP COVER ASS'Y	GH75-01141A	GH75-01141B	GH75-01141C	1	SNA	
	1-4	FRONT COVER	GH72-02545A	GH72-02545B	GH72-02545C	1	SNA	
	1-5	SPONGE LCD	GH74-01449A	GH74-01449A	GH74-01449A	1	SNA	
2		SPEAKER	3001-001221	3001-001221	3001-001221	1	SA	
3		MIC	3003-001063	3003-001063	3003-001063	1	SA	
4		KEY PAD	GH72-02553B	GH72-02553B	GH72-02553B	1	SA	
5		KEY TOP	GH72-02834A	GH72-02834A	GH72-02834A	1	SA	
6		KEY-DOME	GH59-00219A	GH59-00219A	GH59-00219A	1	SA	
7		BUZZER HOLDER	GH73-00729A	GH73-00729A	GH73-00729A	1	SA	
8		BUZZER	3002-001098	3002-001098	3002-001098	1	SA	
9		MAIN PBA	GH92-00998A	GH92-00998A	GH92-00998A	1	SA	
10		LCD	GH07-00075A	GH07-00075A	GH07-00075A	1	SA	
11		RUBBER CONNECTOR	GH73-00678E	GH73-00678F	GH73-00678G	1	SA	
12		COVER SHIELD	GH72-02554A	GH72-02554A	GH72-02554A	1	SA	
13		MOTOR	GH31-00025A	GH31-00025A	GH31-00025A	1	SA	
14	14	REAR COVER ASS'Y	GH75-01142A	GH75-01142B	GH75-01142C	1	SA	
	14-1	COVER EARPHONE	GH73-00730A	GH73-00730B	GH73-00730C	1	SA	
	14-2	BUSHING ANT	GH71-00491A	GH71-00491A	GH71-00491A	1	SA	
	14-3	ANTENNA	GH42-00120C	GH42-00120B	GH42-00120A	1	SA	
	14-4	REAR COVER	GH72-02551A	GH72-02551B	GH72-02551C	1	SNA	
	14-5	SPRING-LOCKER	GH70-10516A	GH70-10516A	GH70-10516A	1	SNA	
	14-6	LOCKER MAIN	GH72-02552A	GH72-02552B	GH72-02552C	1	SNA	
	14-7	SIM SPRING	GH70-00006A	GH70-00006A	GH70-00006A	1	SNA	
	14-8	SIM COVER	GH72-02557A	GH72-02557B	GH72-02557C	1	SNA	
15		MOBILE CAP	GH73-00079D	GH73-00079E	GH73-00079F	1	SNA	
16		SCREW COVER	GH73-00660C	GH73-00660D	GH73-00660E	1	SNA	
17		SCREW M1.7 X 5	6001-001346	6001-001346	6001-001346	5	SA	
18		LABEL(R) ID MAIN	GH68-01944A	GH68-01944A	GH68-01944A	1	SA	
19		BATT ASS'Y(STD)	GH43-00344A	GH43-00344B	GH43-00344C	1	SA	

1-3 Travel Adapter

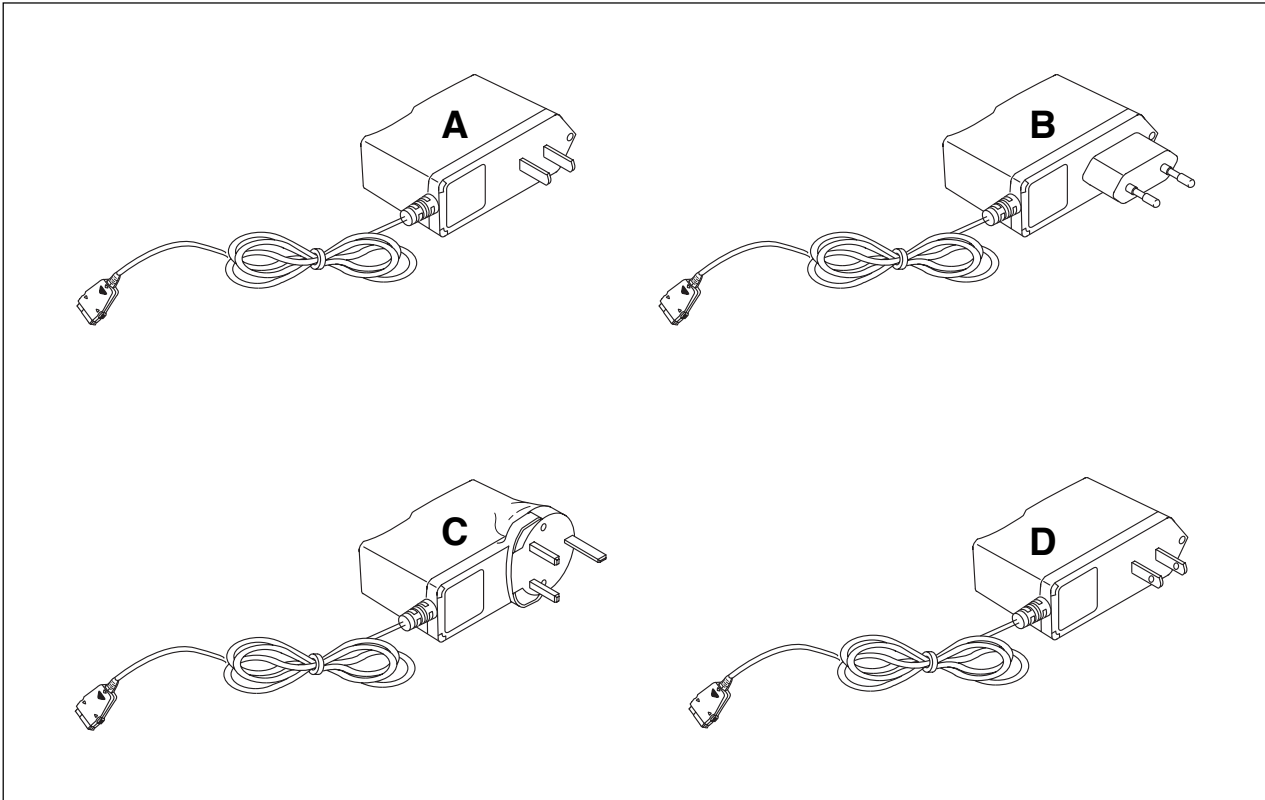

1-4 Travel Adapter Parts List

TYPE	SEC CODE	REMARK
A	GH44-00171A	CHINA
B	GH44-00184A	EUROPE
C	GH44-00171C	UNITED KINGDOM
D	Gh44-00171E	TAIWAN

1-5 Ciger Light Adapter

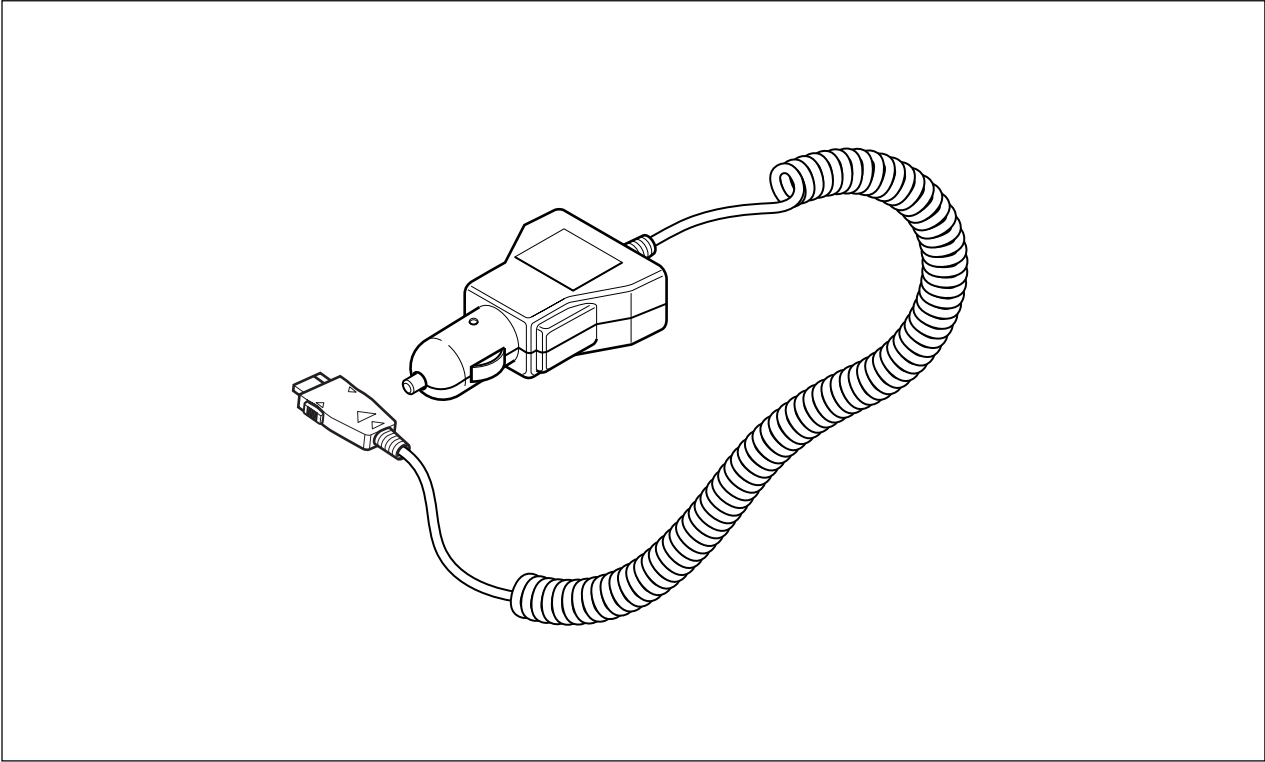

1-6 Ciger Light Adapter Parts List

DESCRIPTION	SEC CODE	REMARK
Ciger Light Adapter Code	GH44-00170A	BLACK

1-7 Test Jig

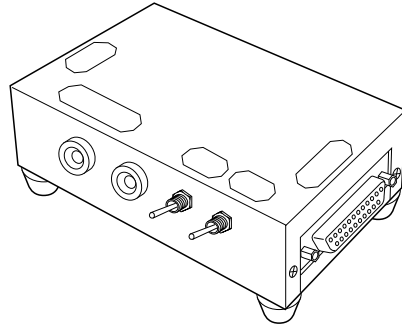

TEST JIG

GH80-10508A

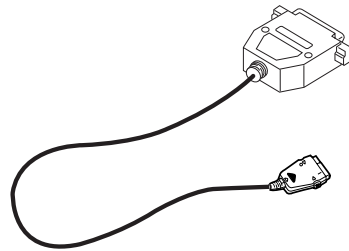

TEST JIG CABLE

GH39-00079A

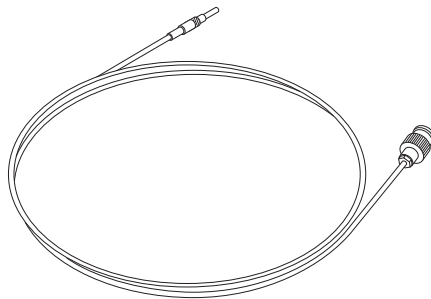

RF CABLE

GH39-00094A

1-7-1 Test Jig

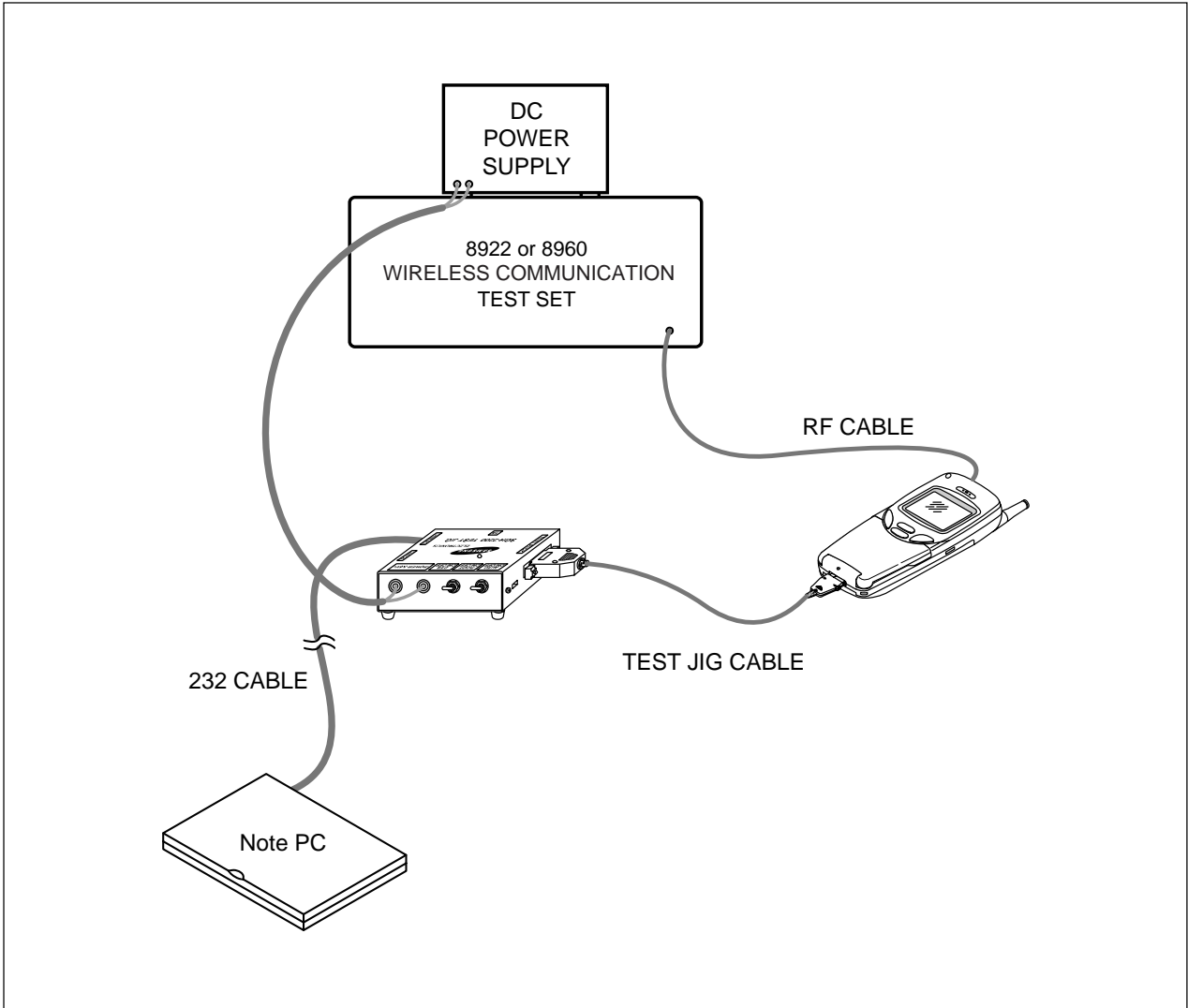

1-8 EAR Microphone

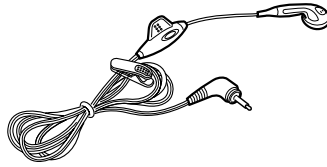

EAR MICROPHONE

GH59-00168A

1-9 Data Kit

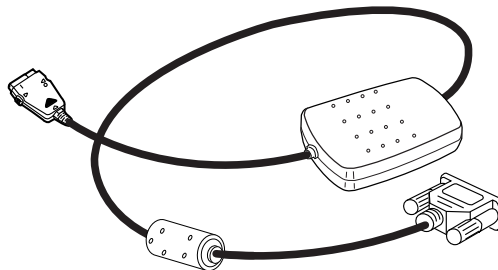

DATA KIT

GH39-00078A

2. PCB Diagrams

2-1 Main Top

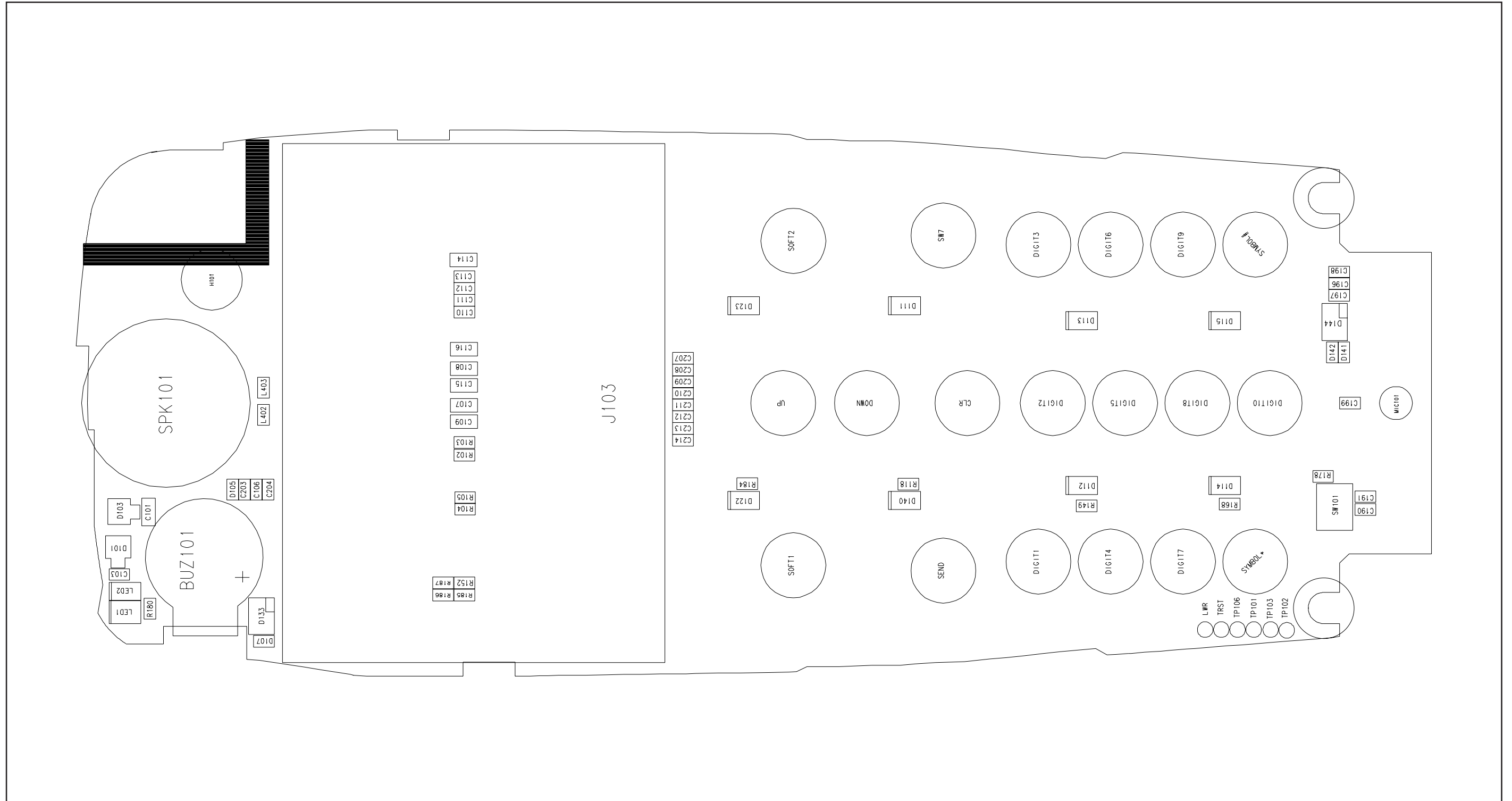

2-2 Main Bottom

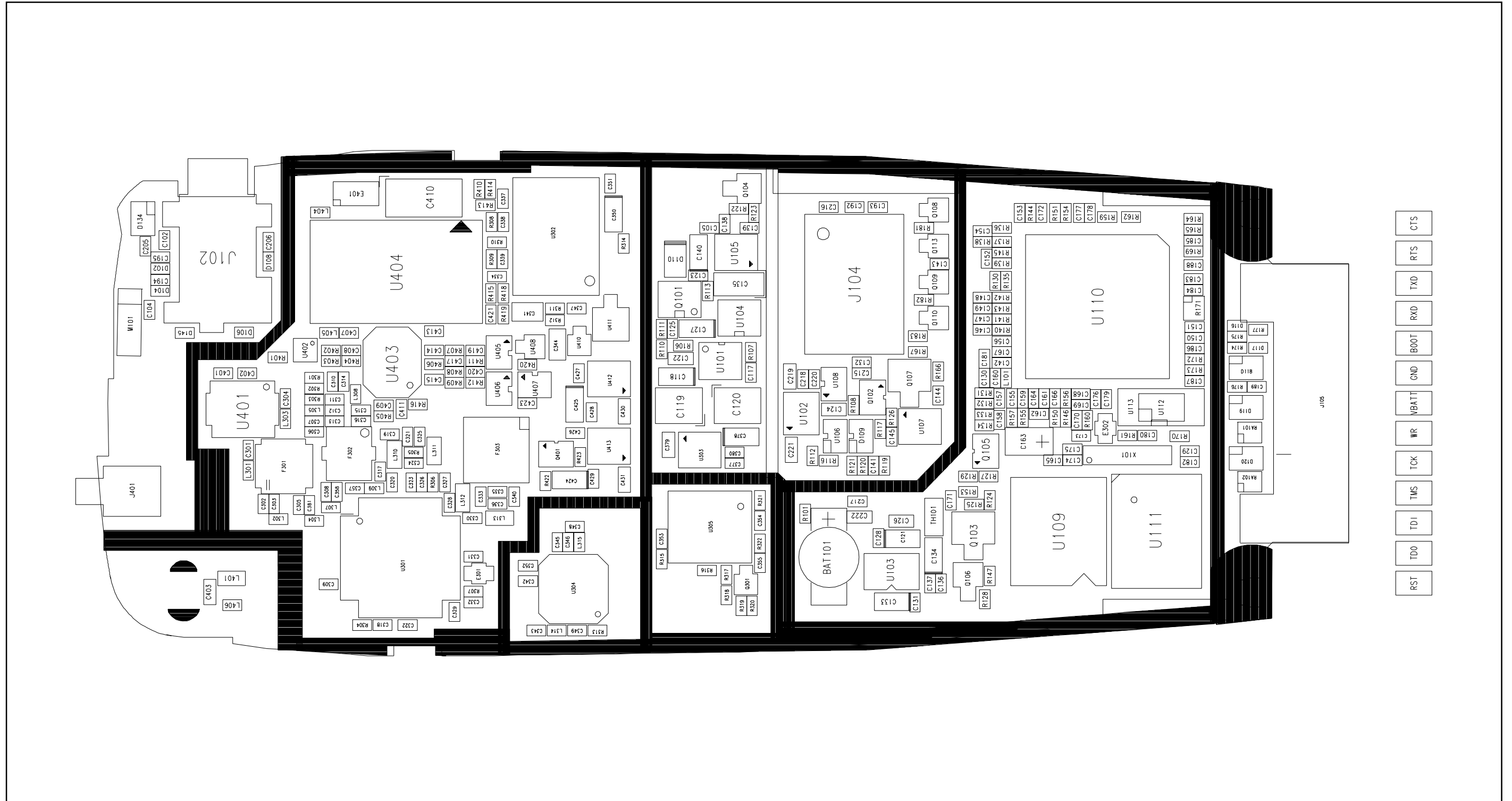

3. Electrical Parts List

3-1 Main Parts List Top

	Reference	SEC CODE	Part Description	Vender Part No
1	BUZ101	3002-001098	BUZZER;BRT-03S	BRT-03S
2	C103	2203-005061	"C-CERAMIC,CHIP;C104Z,100NF,16V"	GRM36Y5V104Z16PT
3	C106	2203-005444	"C-CERAMIC,CHIP;C030B,3PF,50V"	GRP1555C1H3R0BZ01E
4	C107	2203-005065	"C-CERAMIC,CHIP;C105Z,1UF,10V"	GRM39Y5V105Z10PT
5	C108	2203-005065	"C-CERAMIC,CHIP;C105Z,1UF,10V"	GRM39Y5V105Z10PT
6	C109	2203-005065	"C-CERAMIC,CHIP;C105Z,1UF,10V"	GRM39Y5V105Z10PT
7	C110	2203-005061	"C-CERAMIC,CHIP;C104Z,100NF,16V"	GRM36Y5V104Z16PT
8	C111	2203-005061	"C-CERAMIC,CHIP;C104Z,100NF,16V"	GRM36Y5V104Z16PT
9	C112	2203-005061	"C-CERAMIC,CHIP;C104Z,100NF,16V"	GRM36Y5V104Z16PT
10	C113	2203-005061	"C-CERAMIC,CHIP;C104Z,100NF,16V"	GRM36Y5V104Z16PT
11	C114	2203-005065	"C-CERAMIC,CHIP;C105Z,1UF,10V"	GRM39Y5V105Z10PT
12	C115	2203-005065	"C-CERAMIC,CHIP;C105Z,1UF,10V"	GRM39Y5V105Z10PT
13	C116	2203-005065	"C-CERAMIC,CHIP;C105Z,1UF,10V"	GRM39Y5V105Z10PT
14	C190	2203-002443	"C-CERAMIC,CHIP;C331K,330PF,50V"	GRM36X7R331K50PT
15	C199	2203-000995	"C-CERAMIC,CHIP;C470J,47PF,50V"	GRM36C0G470J50PT
16	D101	0407-001002	DIODE;DAN222TL	DAN222TL
17	D111	0601-001094	LED;SLS-NNYG101TS	SLS-NNYG101TS
18	D112	0601-001094	LED;SLS-NNYG101TS	SLS-NNYG101TS
19	D113	0601-001094	LED;SLS-NNYG101TS	SLS-NNYG101TS
20	D114	0601-001094	LED;SLS-NNYG101TS	SLS-NNYG101TS
21	D115	0601-001094	LED;SLS-NNYG101TS	SLS-NNYG101TS
22	D122	0601-001094	LED;SLS-NNYG101TS	SLS-NNYG101TS
23	D123	0601-001094	LED;SLS-NNYG101TS	SLS-NNYG101TS
24	D140	0601-001094	LED;SLS-NNYG101TS	SLS-NNYG101TS
25	D141	1405-001093	COMP-SMD;VC040214X300	VC040214X300
26	D142	1405-001093	COMP-SMD;VC040214X300	VC040214X300
27	D144	0406-001083	DIODE;ESDA6V1W5	ESDA6V1W5
28	U415	0601-001094	LED;SLS-NNYG101TS	SLS-NNYG101TS
29	L402	2703-001986	INDUCTOR-SMD;MLK1005S33NJT	MLK1005S33NJT
30	L403	2703-001986	INDUCTOR-SMD;MLK1005S33NJT	MLK1005S33NJT
31	LED1	0601-001402	LED;CL-165HR/YG-D	CL-165HR/YG-D
32	LED2	0601-001540	LED;SLS-NNBD102TS	SLS-NNBD102TS
33	R102	2007-000148	"R-CHIP;10K,5%"	RC1005J103CS
34	R103	2007-000148	"R-CHIP;10K,5%"	RC1005J103CS
35	R104	2007-000162	"R-CHIP;100K,5%"	RC1005J104CS
36	R105	2007-000162	"R-CHIP;100K,5%"	RC1005J104CS
37	R118	2007-007009	"R-CHIP;75,5%"	RC1005J750CS

	Reference	SEC CODE	Part Description	Vender Part No
38	R149	2007-007009	"R-CHIP;75,5%"	RC1005J750CS
39	R152	2007-000172	"R-CHIP;10,5%"	RC1005J100CS
40	R168	2007-007009	"R-CHIP;75,5%"	RC1005J750CS
41	R178	2007-000143	"R-CHIP;4.7K,5%"	RC1005J472CS
42	R180	2007-007771	"R-CHIP;0,5%"	ERJ2GEJ0R0E
43	R184	2007-007009	"R-CHIP;75,5%"	RC1005J750CS
44	R185	2007-000172	"R-CHIP;10,5%"	RC1005J100CS
45	R187	2007-007771	"R-CHIP;0,5%"	ERJ2GEJ0R0E
46	SW101	1009-001006	IC;A3210ELH	A3210ELH

3-2 Main Parts List Bottom

	Reference	SEC CODE	Part Description	Vender Part No
1	BAT101	4302-001119	BACKUP BATTERY SOCKET;RB414	RB414II06N
2	C101	2203-005065	"C-CERAMIC,CHIP;C105Z,1UF,10V"	GRM39Y5V105Z10PT
3	C102	2203-000812	"C-CERAMIC,CHIP;C330J,33PF,50V"	GRM36C0G330J50PT
4	C104	2203-000679	"C-CERAMIC,CHIP;C270J,27PF,50V"	GRM36C0G270J50PT
5	C117	2203-000254	"C-CERAMIC,CHIP;C103K,10NF,16V"	GRM36X7R103K16PT
6	C118	2404-001105	"C-TA,CHIP;10UF/6.3V"	GRM40X7R682K50PT
7	C119	2404-001134	"C-TA,CHIP;100UF/6.3V"	GRM42-6C0G681J50PT
8	C120	2404-001134	"C-TA,CHIP;100UF/6.3V"	GRM42-6C0G681J50PT
9	C121	2404-001105	"C-TA,CHIP;10UF/6.3V"	GRM40X7R682K50PT
10	C122	2203-005065	"C-CERAMIC,CHIP;C105Z,1UF,10V"	GRM39Y5V105Z10PT
11	C123	2203-000254	"C-CERAMIC,CHIP;C103K,10NF,16V"	GRM36X7R103K16PT
12	C124	2203-005065	"C-CERAMIC,CHIP;C105Z,1UF,10V"	GRM39Y5V105Z10PT
13	C125	2203-005061	"C-CERAMIC,CHIP;C104Z,100NF,16V"	GRM36Y5V104Z16PT
14	C127	2404-001105	"C-TA,CHIP;10UF/6.3V"	GRM40X7R682K50PT
15	C128	2203-000254	"C-CERAMIC,CHIP;C103K,10NF,16V"	GRM36X7R103K16PT
16	C129	2203-005061	"C-CERAMIC,CHIP;C104Z,100NF,16V"	GRM36Y5V104Z16PT
17	C130	2203-000812	"C-CERAMIC,CHIP;C330J,33PF,50V"	GRM36C0G330J50PT
18	C131	2203-000254	"C-CERAMIC,CHIP;C103K,10NF,16V"	GRM36X7R103K16PT
19	C132	2203-000254	"C-CERAMIC,CHIP;C103K,10NF,16V"	GRM36X7R103K16PT
20	C133	2404-001105	"C-TA,CHIP;10UF/6.3V"	GRM40X7R682K50PT
21	C134	2404-001105	"C-TA,CHIP;10UF/6.3V"	GRM40X7R682K50PT
22	C135	2404-001020	"C-TA,CHIP;10UF/10V"	GRM39C0G040C50PT
23	C136	2203-000254	"C-CERAMIC,CHIP;C103K,10NF,16V"	GRM36X7R103K16PT
24	C137	2203-000679	"C-CERAMIC,CHIP;C270J,27PF,50V"	GRM36C0G270J50PT
25	C138	2203-000233	"C-CERAMIC,CHIP;C101J,100PF,50V"	GRM36C0G101J50PT
26	C139	2203-005061	"C-CERAMIC,CHIP;C104Z,100NF,16V"	GRM36Y5V104Z16PT
27	C140	2404-001105	"C-TA,CHIP;10UF/6.3V"	GRM40X7R682K50PT
28	C141	2203-005061	"C-CERAMIC,CHIP;C104Z,100NF,16V"	GRM36Y5V104Z16PT
29	C143	2203-000812	"C-CERAMIC,CHIP;C330J,33PF,50V"	GRM36C0G330J50PT
30	C144	2203-005061	"C-CERAMIC,CHIP;C104Z,100NF,16V"	GRM36Y5V104Z16PT
31	C145	2203-000254	"C-CERAMIC,CHIP;C103K,10NF,16V"	GRM36X7R103K16PT
32	C146	2203-000233	"C-CERAMIC,CHIP;C101J,100PF,50V"	GRM36C0G101J50PT
33	C147	2203-000233	"C-CERAMIC,CHIP;C101J,100PF,50V"	GRM36C0G101J50PT
34	C148	2203-000233	"C-CERAMIC,CHIP;C101J,100PF,50V"	GRM36C0G101J50PT
35	C149	2203-000233	"C-CERAMIC,CHIP;C101J,100PF,50V"	GRM36C0G101J50PT
36	C150	2203-000254	"C-CERAMIC,CHIP;C103K,10NF,16V"	GRM36X7R103K16PT
37	C151	2203-000254	"CCERAMIC,CHIP;C103K,10NF,16V"	GRM36X7R103K16PT
38	C152	2203-000812	"C-CERAMIC,CHIP;C330J,33PF,50V"	GRM36C0G330J50PT
39	C153	2203-000812	"C-CERAMIC,CHIP;C330J,33PF,50V"	GRM36C0G330J50PT

	Reference	SEC CODE	Part Description	Vender Part No
40	C154	2203-000812	"C-CERAMIC,CHIP;C330J,33PF,50V"	GRM36C0G330J50PT
41	C155	2203-003054	"C-CERAMIC,CHIP;C090C,9PF,50V"	GRM36C0G090C50PT
42	C156	2203-005481	"C-CERAMIC,CHIP;C470J,47NF,50V"	GRP155R71A473KA01E
43	C157	2203-005503	"C-CERAMIC,CHIP;C1801J,180PF,25V"	GRM36C0G181J25PT
44	C158	2203-005503	"C-CERAMIC,CHIP;C1801J,180PF,25V"	GRM36C0G181J25PT
45	C159	2203-000679	"C-CERAMIC,CHIP;C270J,27PF,50V"	GRM36C0G270J50PT
46	C160	2203-000254	"C-CERAMIC,CHIP;C103K,10NF,16V"	GRM36X7R103K16PT
47	C161	2203-005480	"C-CERAMIC,CHIP;C333K,33NF,10V"	GRM36X7R333K10PT
48	C162	2203-000812	"C-CERAMIC,CHIP;C330J,33PF,50V"	GRM36C0G330J50PT
49	C163	2404-001162	"C-TA,CHIP;47UF/6.3V"	F950G476MAAJZTQ2
50	C164	2203-005480	"C-CERAMIC,CHIP;C333K,33NF,10V"	GRM36X7R333K10PT
51	C165	2203-005061	"C-CERAMIC,CHIP;C104Z,100NF,16V"	GRM36Y5V104Z16PT
52	C166	2203-003054	"C-CERAMIC,CHIP;C090C,9PF,50V"	GRM36C0G090C50PT
53	C168	2203-000254	"C-CERAMIC,CHIP;C103K,10NF,16V"	GRM36X7R103K16PT
54	C169	2203-000254	"C-CERAMIC,CHIP;C103K,10NF,16V"	GRM36X7R103K16PT
55	C170	2203-000254	"C-CERAMIC,CHIP;C103K,10NF,16V"	GRM36X7R103K16PT
56	C171	2203-005061	"C-CERAMIC,CHIP;C104Z,100NF,16V"	GRM36Y5V104Z16PT
57	C172	2203-000812	"C-CERAMIC,CHIP;C330J,33PF,50V"	GRM36C0G330J50PT
58	C173	2203-005061	"C-CERAMIC,CHIP;C104Z,100NF,16V"	GRM36Y5V104Z16PT
59	C174	2203-003054	"C-CERAMIC,CHIP;C090C,9PF,50V"	GRM36C0G090C50PT
60	C175	2203-003054	"C-CERAMIC,CHIP;C090C,9PF,50V"	GRM36C0G090C50PT
61	C176	2203-000254	"C-CERAMIC,CHIP;C103K,10NF,16V"	GRM36X7R103K16PT
62	C177	2203-000254	"C-CERAMIC,CHIP;C103K,10NF,16V"	GRM36X7R103K16PT
63	C178	2203-000812	"C-CERAMIC,CHIP;C330J,33PF,50V"	GRM36C0G330J50PT
64	C179	2203-000812	"C-CERAMIC,CHIP;C330J,33PF,50V"	GRM36C0G330J50PT
65	C180	2203-000254	"C-CERAMIC,CHIP;C103K,10NF,16V"	GRM36X7R103K16PT
66	C181	2203-005482	"C-CERAMIC,CHIP;C104Z,100NF,10V"	GRP155R61A104KA01E
67	C182	2203-005061	"C-CERAMIC,CHIP;C104Z,100NF,16V"	GRM36Y5V104Z16PT
68	C183	2203-000812	"C-CERAMIC,CHIP;C330J,33PF,50V"	GRM36C0G330J50PT
69	C184	2203-000254	"C-CERAMIC,CHIP;C103K,10NF,16V"	GRM36X7R103K16PT
70	C185	2203-000812	"C-CERAMIC,CHIP;C330J,33PF,50V"	GRM36C0G330J50PT
71	C186	2203-000812	"C-CERAMIC,CHIP;C330J,33PF,50V"	GRM36C0G330J50PT
72	C187	2203-000812	"C-CERAMIC,CHIP;C330J,33PF,50V"	GRM36C0G330J50PT
73	C188	2203-000812	"C-CERAMIC,CHIP;C330J,33PF,50V"	GRM36C0G330J50PT
74	C189	2203-005061	"C-CERAMIC,CHIP;C104Z,100NF,16V"	GRM36Y5V104Z16PT
75	C192	2203-000233	"C-CERAMIC,CHIP;C101J,100PF,50V"	GRM36C0G101J50PT
76	C193	2203-000233	"C-CERAMIC,CHIP;C101J,100PF,50V"	GRM36C0G101J50PT
77	C217	2203-005061	"C-CERAMIC,CHIP;C104Z,100NF,16V"	GRM36Y5V104Z16PT
78	C218	2203-000254	"C-CERAMIC,CHIP;C103K,10NF,16V"	GRM36X7R103K16PT
79	C219	2203-005065	"C-CERAMIC,CHIP;C105Z,1UF,10V"	GRM39Y5V105Z10PT
80	C221	2203-005065	"C-CERAMIC,CHIP;C105Z,1UF,10V"	GRM39Y5V105Z10PT
81	C222	2203-005065	"C-CERAMIC,CHIP;C105Z,1UF,10V"	GRM39Y5V105Z10PT

	Reference	SEC CODE	Part Description	Vender Part No
82	C301	2203-000812	"C-CERAMIC,CHIP;C330J,33PF,50V"	GRM36C0G330J50PT
83	C302	2203-005446	"C-CERAMIC,CHIP;C2R7B,2.7PF,50V"	GRM36COG2R7B50PT
84	C303	2203-000679	"C-CERAMIC,CHIP;C270J,27PF,50V"	GRM36C0G270J50PT
85	C304	2203-000233	"C-CERAMIC,CHIP;C101J,100PF,50V"	GRM36C0G101J50PT
86	C305	2203-000233	"C-CERAMIC,CHIP;C101J,100PF,50V"	GRM36C0G101J50PT
87	C306	2203-005050	"C-CERAMIC,CHIP;1.8pF,16V"	GRM36C0G1R8C50PT
88	C307	2203-000812	"C-CERAMIC,CHIP;C330J,33PF,50V"	GRM36C0G330J50PT
89	C309	2203-000438	"C-CERAMIC,CHIP;C102K,1NF,50V"	GRM36X7R102K50PT
90	C310	2203-000679	"C-CERAMIC,CHIP;C270J,27PF,50V"	GRM36C0G270J50PT
91	C311	2203-000438	"C-CERAMIC,CHIP;C102K,1NF,50V"	GRM36X7R102K50PT
92	C312	2203-000278	"C-CERAMIC,CHIP;C100D,10PF,50V"	GRM36C0G100D50PT
93	C313	2203-000233	"C-CERAMIC,CHIP;C101J,100PF,50V"	GRM36C0G101J50PT
94	C314	2203-000438	"C-CERAMIC,CHIP;C102K,1NF,50V"	GRM36X7R102K50PT
95	C315	2203-000679	"C-CERAMIC,CHIP;C270J,27PF,50V"	GRM36C0G270J50PT
96	C318	2203-002687	"C-CERAMIC,CHIP;C122K,1.2NF,50V"	GRM36X7R122K50PT
97	C319	2203-000254	"C-CERAMIC,CHIP;C103K,10NF,16V"	GRM36X7R103K16PT
98	C320	2203-000438	"C-CERAMIC,CHIP;C102K,1NF,50V"	GRM36X7R102K50PT
99	C321	2203-000995	"C-CERAMIC,CHIP;C470J,47PF,50V"	GRM36C0G470J50PT
100	C322	2203-000438	"C-CERAMIC,CHIP;C102K,1NF,50V"	GRM36X7R102K50PT
101	C323	2203-000438	"C-CERAMIC,CHIP;C102K,1NF,50V"	GRM36X7R102K50PT
102	C324	2203-001385	"C-CERAMIC,CHIP;C1R5C,1.5PF,50V"	GRM36C0G1R5C50PT
103	C325	2203-000995	"C-CERAMIC,CHIP;C470J,47PF,50V"	GRM36C0G470J50PT
104	C326	2203-000438	"C-CERAMIC,CHIP;C102K,1NF,50V"	GRM36X7R102K50PT
105	C327	2203-000438	"C-CERAMIC,CHIP;C102K,1NF,50V"	GRM36X7R102K50PT
106	C328	2203-000359	"C-CERAMIC,CHIP;C151J,150PF,50V"	GRM36C0G151J50PT
107	C329	2203-000254	"C-CERAMIC,CHIP;C103K,10NF,16V"	GRM36X7R103K16PT
108	C330	2203-000438	"C-CERAMIC,CHIP;C102K,1NF,50V"	GRM36X7R102K50PT
109	C331	2203-000679	"C-CERAMIC,CHIP;C270J,27PF,50V"	GRM36C0G270J50PT
110	C332	2203-000438	"C-CERAMIC,CHIP;C102K,1NF,50V"	GRM36X7R102K50PT
111	C333	2203-000995	"C-CERAMIC,CHIP;C470J,47PF,50V"	GRM36C0G470J50PT
112	C334	2203-000812	"C-CERAMIC,CHIP;C330J,33PF,50V"	GRM36C0G330J50PT
113	C336	2203-000870	"C-CERAMIC,CHIP;C030C,3PF,50V"	GRM36COG030C50PT
114	C337	2203-000233	"C-CERAMIC,CHIP;C101J,100PF,50V"	GRM36C0G101J50PT
115	C338	2203-000679	"C-CERAMIC,CHIP;C270J,27PF,50V"	GRM36C0G270J50PT
116	C339	2203-000812	"C-CERAMIC,CHIP;C330J,33PF,50V"	GRM36C0G330J50PT
117	C340	2203-000995	"C-CERAMIC,CHIP;C470J,47PF,50V"	GRM36C0G470J50PT
118	C341	2301-001232	"C-CERAMIC,CHIP;470PF,50V"	ECHU1H471JX5
119	C342	2203-005061	"C-CERAMIC,CHIP;C104Z,100NF,16V"	GRM36Y5V104Z16PT
120	C343	2203-002525	"C-CERAMIC,CHIP;C561K,560PF,50V"	GRM36X7R561K50PT
121	C344	2203-000609	"C-CERAMIC,CHIP;C223K,22NF,50V"	RM40X7R223K50PT
122	C345	2203-000585	"C-CERAMIC,CHIP;C221K,220PF,50V"	ECUE1H221KBQ
123	C346	2203-005061	"C-CERAMIC,CHIP;C104Z,100NF,16V"	GRM36Y5V104Z16PT

	Reference	SEC CODE	Part Description	Vender Part No
124	C348	2203-002525	"C-CERAMIC,CHIP;C561K,560PF,50V"	GRM36X7R561K50PT
125	C349	2203-005061	"C-CERAMIC,CHIP;C104Z,100NF,16V"	GRM36Y5V104Z16PT
126	C350	2404-001101	"C-TA,CHIP;1UF/16V"	TAJR105M016R
127	C351	2203-000438	"C-CERAMIC,CHIP;C102K,1NF,50V"	GRM36X7R102K50PT
128	C352	2203-002525	"C-CERAMIC,CHIP;C561K,560PF,50V"	GRM36X7R561K50PT
129	C353	2203-000254	"C-CERAMIC,CHIP;C103K,10NF,16V"	GRM36X7R103K16PT
130	C354	2203-000254	"C-CERAMIC,CHIP;C103K,10NF,16V"	GRM36X7R103K16PT
131	C355	2203-000254	"C-CERAMIC,CHIP;C103K,10NF,16V"	GRM36X7R103K16PT
132	C357	2203-000233	"C-CERAMIC,CHIP;C101J,100PF,50V"	GRM36C0G101J50PT
133	C358	2203-005393	"C-CERAMIC,CHIP;C050B,5PF,50V"	GRM36C0G050B50PT
134	C377	2203-000254	"C-CERAMIC,CHIP;C103K,10NF,16V"	GRM36X7R103K16PT
135	C378	2404-001105	"C-TA,CHIP;10UF/6.3V"	GRM40X7R682K50PT
136	C379	2203-005065	"C-CERAMIC,CHIP;C105Z,1UF,10V"	GRM39Y5V105Z10PT
137	C380	2203-005061	"C-CERAMIC,CHIP;C104Z,100NF,16V"	GRM36Y5V104Z16PT
138	C381	2203-000466	"C-CERAMIC,CHIP;C010C,1PF,50V"	GRM36C0G010C50PT
139	C401	2203-000233	"C-CERAMIC,CHIP;C101J,100PF,50V"	GRM36C0G101J50PT
140	C402	2203-000812	"C-CERAMIC,CHIP;C330J,33PF,50V"	GRM36C0G330J50PT
141	C403	2203-000697	"C-CERAMIC,CHIP;C020C,2PF,50V"	GRM39C0G020C50PT
142	C407	2203-000233	"C-CERAMIC,CHIP;C101J,100PF,50V"	GRM36C0G101J50PT
143	C408	2203-000995	"C-CERAMIC,CHIP;C470J,47PF,50V"	GRM36C0G470J50PT
144	C409	2203-001124	"C-CERAMIC,CHIP;C681K,680PF,50V"	GRM36X7R681K50PT
145	C410	2404-001210	"C-TA,CHIP;220UF/6.3V"	F750J227MUCGZT
146	C411	2203-000812	"C-CERAMIC,CHIP;C330J,33PF,50V"	GRM36C0G330J50PT
147	C413	2203-000679	"C-CERAMIC,CHIP;C270J,27PF,50V"	GRM36C0G270J50PT
148	C414	2203-000679	"C-CERAMIC,CHIP;C270J,27PF,50V"	GRM36C0G270J50PT
149	C415	2203-000311	"C-CERAMIC,CHIP;C121J,120PF,50V"	GRM36C0G121J50PT
150	C417	2203-001239	"C-CERAMIC,CHIP;C820J,82PF,50V"	GRM36C0G820J50PT
151	C419	2203-000679	"C-CERAMIC,CHIP;C270J,27PF,50V"	GRM36C0G270J50PT
152	C420	2203-000679	"C-CERAMIC,CHIP;C270J,27PF,50V"	GRM36C0G270J50PT
153	C421	2203-000812	"C-CERAMIC,CHIP;C330J,33PF,50V"	GRM36C0G330J50PT
154	C423	2203-000438	"C-CERAMIC,CHIP;C102K,1NF,50V"	GRM36X7R102K50PT
155	C424	2404-001105	"C-TA,CHIP;10UF/6.3V"	GRM40X7R682K50PT
156	C425	2404-001105	"C-TA,CHIP;10UF/6.3V"	GRM40X7R682K50PT
157	C428	2203-005061	"C-CERAMIC,CHIP;C104Z,100NF,16V"	GRM36Y5V104Z16PT
158	C429	2203-005061	"C-CERAMIC,CHIP;C104Z,100NF,16V"	GRM36Y5V104Z16PT
159	C430	2203-005065	"C-CERAMIC,CHIP;C105Z,1UF,10V"	GRM39Y5V105Z10PT
160	C431	2203-005065	"C-CERAMIC,CHIP;C105Z,1UF,10V"	GRM39Y5V105Z10PT
161	D102	1405-001093	COMP-SMD;VC040214X300	VC040214X300
162	D103	0407-001002	DIODE;DAN222TL	DAN222
163	D104	1405-001093	VARISTOR;VC040214X300	VC040214X300
164	D105	1405-001093	VARISTOR;VC040214X300	VC040214X300
165	D106	1405-001093	VARISTOR;VC040214X300	VC040214X300

	Reference	SEC CODE	Part Description	Vender Part No
166	D107	1405-001093	VARISTOR;VC040214X300	VC040214X300
167	D108	1405-001093	VARISTOR;VC040214X300	VC040214X300
168	D109	0407-001007	DIODE;UMN1	DAN222
169	D110	0401-001033	DIODE;MCL4154	MCL4154
170	D116	1405-001093	COMP-SMD;VC040214X300	VC040214X300
171	D117	1405-001093	COMP-SMD;VC040214X300	VC040214X300
172	D118	0406-001083	DIODE;ESDA6V1W5	ESDA6V1W5
173	D119	0406-001083	DIODE;ESDA6V1W5	ESDA6V1W5
174	D120	0406-001083	DIODE;ESDA6V1W5	ESDA6V1W5
175	D121	0406-001083	DIODE;ESDA6V1W5	ESDA6V1W5
176	D134	0406-001083	DIODE;ESDA6V1W5	ESDA6V1W5
177	D145	1405-001093	VARISTOR;VC040214X300	VC040214X300
178	E301	2901-001116	FILTER-EMI SMD;NFM39R12C471T1	NFM2012R13C471R
179	E302	2901-001116	FILTER-EMI SMD;NFM39R12C471T1	NFM2012R13C471R
180	E401	2901-001155	FILTER-EMI SMD;NFM60R00T221	NFM60R00T221
181	F301	2904-001235	FILTER-SAW;FAR-G6CH-1G8425-L218	FAR-G6CH-1G8425-L218
182	F302	2904-001300	FILTER-SAW;FAR-G6CH-1G8425-L227B	FAR-G6CH-1G8425-L227B
183	F303	2904-001302	FILTER-SAW;B4846	B4846
184	J102	3722-001380	CONNECTOR;02-787B2-53BKA	02-787B3-53BKA
185	J104	3709-001121	CONNECTOR;1-338063-9	1-338063-9
186	J105	3710-001595	CONNECTOR;1004-0018-304	1004-0018-304
187	J401	3705-001242	CONNECTOR;CRS5001-1702	CRS5001-1702
188	L101	2703-001752	INDUCTOR-SMD;LL1005-FH39NJ	LL1005-FH39NJ
189	L301	2703-001409	INDUCTOR-SMD;LL1005-F12NK	LL1005-FH12NK
190	L302	2703-001734	INDUCTOR-SMD;LL1005-FH6N8J	LL1005-FH6N8J
191	L303	2703-001748	INDUCTOR-SMD;LL1005-FH5N6S	LL1005-FH5N6S
192	L304	2703-001750	INDUCTOR-SMD;LL1005-FH2N2S	LL1005-FH2N2S
193	L305	2703-001727	INDUCTOR-SMD;HK1005-22NJ-T	HK1005-22NJ-T
194	L307	2703-001747	INDUCTOR-SMD;LL1005-FH4N7S	LL1005-FH4N7S
195	L308	2703-001178	INDUCTOR-SMD;LL1005-FH3N3S	LL1005-FH3N3S
196	L309	2703-001727	INDUCTOR-SMD;HK1005-22NJ-T	HK1005-22NJ-T
197	L310	2703-001545	INDUCTOR-SMD;0603CS-47NXJBC	0603CS-47NXJBC
198	L311	2703-001545	INDUCTOR-SMD;0603CS-47NXJBC	0603CS-47NXJBC
199	L312	2703-001685	INDUCTOR-SMD;0603CS-82NXJBC	0603CS-82NXJBC
200	L313	2703-001514	INDUCTOR-SMD;0603CS-68NXJBC	0603CS-68NXJBC
201	L314	2703-001786	INDUCTOR-SMD;LL1005-FH10NJ	LL1005-FH10NJ
202	L315	2703-001750	INDUCTOR-SMD;LL1005-FH2N2S	LL1005-FH2N2S
203	L401	2703-001308	INDUCTOR-SMD;HK1608-68NJ-T	HK1608-68NJ-T
204	L404	2703-001970	INDUCTOR-SMD;HK1005-18NJ-T	HK1005-18NJ-T
205	L405	2703-001734	INDUCTOR-SMD;LL1005-FH6N8J	LL1005-FH6N8J
206	L406	2703-001178	INDUCTOR-SMD;LL1005-FH3N3S	LL1005-FH3N3S
207	M101	3710-001105	CONNECTOR;24-8005-002-000-867	24-8005-002-000-867

	Reference	SEC CODE	Part Description	Vender Part No
208	Q101	0502-001201	TR-POWER;ZXT13P20DE6	ZXT13P20DE6
209	Q102	0505-001423	IC;FDG63231	FDG6323L
210	Q103	0501-002011	TR-SMALL SIGNAL;2SD2114KT146V	2SD2114KT146V
211	Q104	0501-000162	TR-SMALL SIGNAL;2SA1576FRT106	2SA1576FRT106
212	Q105	0505-001332	IC;FDG6301N	FDG6301N
213	Q106	0501-000162	TR-SMALL SIGNAL;2SA1576FRT106	2SA1576FRT106
214	Q107	0501-002011	TR-SMALL SIGNAL;2SD2114KT146V	2SD2114KT146V
215	Q108	0504-001012	TR-SMALL SIGNAL;DTC114YE	DTC114YE
216	Q109	0504-001012	TR-SMALL SIGNAL;DTC114YE	DTC114YE
217	Q110	0504-001012	TR-SMALL SIGNAL;DTC114YE	DTC114YE
218	Q113	0504-000167	TR-SMALL SIGNAL;DTC114EE/TR	DTC114EE/TR
219	Q301	0501-000225	TR-SMALL SIGNAL;2SC4617	2SC4617R
220	Q401	0505-001423	IC;FDG63231	FDG6323L
221	R101	2007-000140	"R-CHIP;1K,5%"	RC1005J102CS
222	R106	2007-000140	"R-CHIP;1K,5%"	RC1005J102CS
223	R107	2007-000162	"R-CHIP;100K,5%"	RC1005J104CS
224	R108	2007-000148	"R-CHIP;10K,5%"	RC1005J103CS
225	R110	2007-007107	"R-CHIP;100K,1%"	RC1005F1003CS
226	R111	2007-007590	"R-CHIP;82K,1%"	RK73H1ETP8202F
227	R112	2007-000148	"R-CHIP;10K,5%"	RC1005J103CS
228	R113	2007-007317	"R-CHIP;2.2K,1%"	RK73H1ETP2201F
229	R116	2007-000162	"R-CHIP;100K,5%"	RC1005J104CS
230	R117	2007-000148	"R-CHIP;10K,5%"	RC1005J103CS
231	R119	2007-000148	"R-CHIP;10K,5%"	RC1005J103CS
232	R120	2007-000162	"R-CHIP;100K,5%"	RC1005J104CS
233	R121	2007-000148	"R-CHIP;10K,5%"	RC1005J103CS
234	R122	2007-000143	"R-CHIP;4.7K,5%"	RC1005J472CS
235	R123	2007-000138	"R-CHIP;100,5%"	RC1005J101CS
236	R124	2007-000143	"R-CHIP;4.7K,5%"	RC1005J472CS
237	R125	2007-000162	"R-CHIP;100K,5%"	RC1005J104CS
238	R126	2007-000148	"R-CHIP;10K,5%"	RC1005J103CS
239	R127	2007-000162	"R-CHIP;100K,5%"	RC1005J104CS
240	R128	2007-000148	"R-CHIP;10K,5%"	RC1005J103CS
241	R129	2007-000162	"R-CHIP;100K,5%"	RC1005J104CS
242	R130	2007-000148	"R-CHIP;10K,5%"	RC1005J103CS
243	R131	2007-007318	"R-CHIP;1K,1%"	RK73H1ETP1001F
244	R132	2007-007318	"R-CHIP;1K,1%"	RK73H1ETP1001F
245	R133	2007-007318	"R-CHIP;1K,1%"	RK73H1ETP1001F
246	R134	2007-007318	"R-CHIP;1K,1%"	RK73H1ETP1001F
247	R136	2007-000168	"R-CHIP;470K,5%"	RC1005J474CS
248	R137	2007-000148	"R-CHIP;10K,5%"	RC1005J103CS
249	R138	2007-000148	"R-CHIP;10K,5%"	RC1005J103CS

	Reference	SEC CODE	Part Description	Vender Part No
250	R139	2007-000157	"R-CHIP;47K,5%"	RC1005J473CS
251	R140	2007-007317	"R-CHIP;2.2K,1%"	RK73H1ETP2201F
252	R141	2007-007317	"R-CHIP;2.2K,1%"	RK73H1ETP2201F
253	R142	2007-007317	"R-CHIP;2.2K,1%"	RK73H1ETP2201F
254	R143	2007-007317	"R-CHIP;2.2K,1%"	RK73H1ETP2201F
255	R144	2007-000157	"R-CHIP;47K,5%"	RC1005J473CS
256	R145	2007-000157	"R-CHIP;47K,5%"	RC1005J473CS
257	R146	2007-000139	"R-CHIP;220,5%"	RC1005J221CS
258	R147	2007-000148	"R-CHIP;10K,5%"	RC1005J103CS
259	R150	2007-002796	"R-CHIP;510,5%"	RK73K1ETP511J
260	R151	2007-000162	"R-CHIP;100K,5%"	RC1005J104CS
261	R153	2007-000159	"R-CHIP;56K,5%"	RC1005J563CS
262	R154	2007-000162	"R-CHIP;100K,5%"	RC1005J104CS
263	R155	2007-002796	"R-CHIP;510,5%"	RK73K1ETP511J
264	R156	2007-000148	"R-CHIP;10K,5%"	RC1005J103CS
265	R157	2007-000139	"R-CHIP;220,5%"	RC1005J221CS
266	R159	2007-000152	"R-CHIP;20K,5%"	RC1005J203CS
267	R160	2007-000148	"R-CHIP;10K,5%"	RC1005J103CS
268	R161	2007-000148	"R-CHIP;10K,5%"	RC1005J103CS
269	R162	2007-000148	"R-CHIP;10K,5%"	RC1005J103CS
270	R165	2007-000148	"R-CHIP;10K,5%"	RC1005J103CS
271	R166	2007-000162	"R-CHIP;100K,5%"	RC1005J104CS
272	R167	2007-000140	"R-CHIP;1K,5%"	RC1005J102CS
273	R169	2007-000162	"R-CHIP;100K,5%"	RC1005J104CS
274	R170	2007-000148	"R-CHIP;10K,5%"	RC1005J103CS
275	R171	2011-001345	R-CHIP;EXB28V103JX	EXB28V103JX
276	R172	2007-000141	"R-CHIP;2.2K,5%"	914C101X2SR
277	R173	2007-000141	"R-CHIP;2.2K,5%"	914C101X2SR
278	R174	2007-000172	"R-CHIP;10,5%"	DA10S103CG
279	R175	2007-000172	"R-CHIP;10,5%"	DA10S103CG
280	R176	2007-000138	"R-CHIP;100,5%"	RC1005J101CS
281	R177	2007-007771	"R-CHIP;0,5%"	ERJ2GEJ0R0E
282	R181	2007-001306	"R-CHIP;150,5%"	RC1005J151CS
283	R182	2007-000172	"R-CHIP;10,5%"	RC1005J100CS
284	R183	2007-001311	"R-CHIP;270,5%"	RC1005J271CS
285	R301	2007-000172	"R-CHIP;10,5%"	RC1005J100CS
286	R302	2007-000172	"R-CHIP;10,5%"	RC1005J100CS
287	R304	2007-001333	"R-CHIP;18K,5%"	RC1005J183CS
288	R305	2007-000141	"R-CHIP;2.2K,5%"	914C101X2SR
289	R306	2007-001298	"R-CHIP;51,5%"	RC1005J510CS
290	R307	2007-000174	"R-CHIP;47,5%"	RC1005J470CS
291	R308	2007-000138	"R-CHIP;100,5%"	RC1005J101CS

	Reference	SEC CODE	Part Description	Vender Part No
292	R309	2007-001313	"R-CHIP;330,5%"	RC1005J331CS
293	R310	2007-000174	"R-CHIP;47,5%"	RC1005J470CS
294	R311	2007-000138	"R-CHIP;100,5%"	RC1005J101CS
295	R312	2007-001292	"R-CHIP;33,5%"	ERJ2GEJ330X
296	R313	2007-000242	"R-CHIP;1.5K,5%"	ERJ2GEJ152X
297	R314	2007-007771	"R-CHIP;0,5%"	ERJ2GEJ0R0E
298	R315	2007-000140	"R-CHIP;1K,5%"	RC1005J102CS
299	R316	2007-001325	"R-CHIP;3.3K,5%"	RC1005J332CS
300	R317	2007-001244	"R-CHIP;91K,5%"	RC1005J913CS
301	R318	2007-000155	"R-CHIP;27K,5%"	RC1005J273CS
302	R319	2007-000140	"R-CHIP;1K,5%"	RC1005J102CS
303	R320	2007-001307	"R-CHIP;180,5%"	RC1005J181CS
304	R321	2007-000148	"R-CHIP;10K,5%"	RC1005J103CS
305	R322	2007-000172	"R-CHIP;10,5%"	RC1005J100CS
306	R401	2007-001298	"R-CHIP;51,5%"	RC1005J510CS
307	R402	2007-001301	"R-CHIP;68,5%"	RC1005J680CS
308	R403	2007-001307	"R-CHIP;180,5%"	RC1005J181CS
309	R404	2007-001301	"R-CHIP;68,5%"	RC1005J680CS
310	R405	2007-007314	"R-CHIP;5.6K,1%"	MCR01MZSF5601
311	R406	2007-007311	"R-CHIP;22K,1%"	ERJ2RKF2202X
312	R407	2007-000148	"R-CHIP;10K,5%"	RC1005J103CS
313	R408	2007-007142	"R-CHIP;10K,1%"	ERJ2GEF103X
314	R409	2007-007142	"R-CHIP;10K,1%"	ERJ2GEF103X
315	R410	2007-007008	"R-CHIP;300,5%"	RC1005J301CS
316	R411	2007-000148	"R-CHIP;10K,5%"	RC1005J103CS
317	R412	2007-000148	"R-CHIP;10K,5%"	RC1005J103CS
318	R413	2007-001288	"R-CHIP;18,5%"	RC1005J180CS
319	R414	2007-007008	"R-CHIP;300,5%"	RC1005J301CS
320	R415	2007-001298	"R-CHIP;51,5%"	RC1005J510CS
321	R418	2007-001305	"R-CHIP;120,5%"	RC1005J121CS
322	R419	2007-001305	"R-CHIP;120,5%"	RC1005J121CS
323	R420	2007-000148	"R-CHIP;10K,5%"	RC1005J103CS
324	R422	2007-000148	"R-CHIP;10K,5%"	RC1005J103CS
325	R423	2007-000148	"R-CHIP;10K,5%"	RC1005J103CS
326	RA101	2011-001344	R-CHIP;CRB2A4E101JT	EXB28V101JX
327	RA102	2011-001344	R-CHIP;CRB2A4E101JT	EXB28V101JX
328	TH101	1404-001005	IC;NTH5G40B473J01TE	NTH5G20P40B473J07TE
329	U101	0505-001376	IC;SI3865DV	SI3865DV
330	U102	1203-002077	REGULATOR IC;LP2985AIM5X-3.0	LP2985AIM5X-3.0
331	U103	1203-001979	LDO;R5320G003A-TP	R5320G003A-TP
332	U104	1203-002127	BATTERY IC;LTC1734ES6-4.2#TR	LTC1734ES6-4.2#TR
333	U105	1203-002077	REGULATOR IC;LP2985AIM5X-3.0	LP2985AIM5X-3.0

	Reference	SEC CODE	Part Description	Vender Part No
334	U106	0506-001004	TR-ARRAY;UMC5NTL	UMC5NTR
335	U107	1203-002247	RESET IC;S-80926ALMP-DAP-T2	S-80926ALMP-DAP-T2
336	U108	0504-001058	TR-SMALL SIGNAL;RN4985	RN4985-TE85L
337	U109	1107-001304	MEMORY IC;AM29DL162DT-90WCI	AM29DL162DT-90WCI
338	U110	1205-001881	ONE-C;VP40575	VP40575
339	U111	1106-001326	IC;KM616U4110CLZI-7L	KM616FU4110CFI-7
340	U113	1103-001185	EEPROM IC;S524AD0XF1	S524AD0XF1
341	U301	1205-001935	BRIGHT2 PLUS IC;HD155128TF	HD155128TF
342	U302	2806-001239	OSCILLATOR;VOF1748C28KRJ	VOF1748C28KRF
343	U303	1203-001701	REGULATOR IC;LP2982AIM5X-3.0	LP2982AIM5X-3.0
344	U304	1209-001337	IC;SI4133-MLP28	SI4133-MLP28
345	U305	2809-001237	OSCILLATOR;TCO-9131B(13MHz)	TCO-9131B(13MHz)
346	U401	2909-001146	ANTENNA SWITCH;LMG002S-5008C	LMG002S-5008C
347	U402	4709-001144	COUPLER-DIRECTION;LDC15D190A0007A	LDC15D190A0007A
348	U403	1209-001354	IC;HD155173NP	HD155173NP
349	U404	1201-001689	PAM IC;PF08107B	PF08107B
350	U405	0504-001058	TR-SMALL SIGNAL;RN4985	RN4985-TE85L
351	U406	0504-001058	TR-SMALL SIGNAL;RN4985	RN4985-TE85L
352	U407	0504-001058	TR-SMALL SIGNAL;RN4985	RN4985-TE85L
353	U408	0504-001012	TR-SMALL SIGNAL;DTC114YE	DTC114YE
354	U410	0504-000167	TR-SMALL SIGNAL;DTC114EE/TR	DTC114EE/TR
355	U411	0504-001021	TR-SMALL SIGNAL;DTB113ZK	DTB113ZK
356	U412	1203-001454	REGULATOR IC;LP2981AIM5X-3.0	LP2981AIM5X-3.0
357	U413	1203-001701	REGULATOR IC;LP2982AIM5X-3.0	LP2982AIM5X-3.0
358	X101	2801-003856	OSCILLATOR;MC-146	MC-146(32.768KHz)

4. Block Diagrams

4-1 Main Baseband

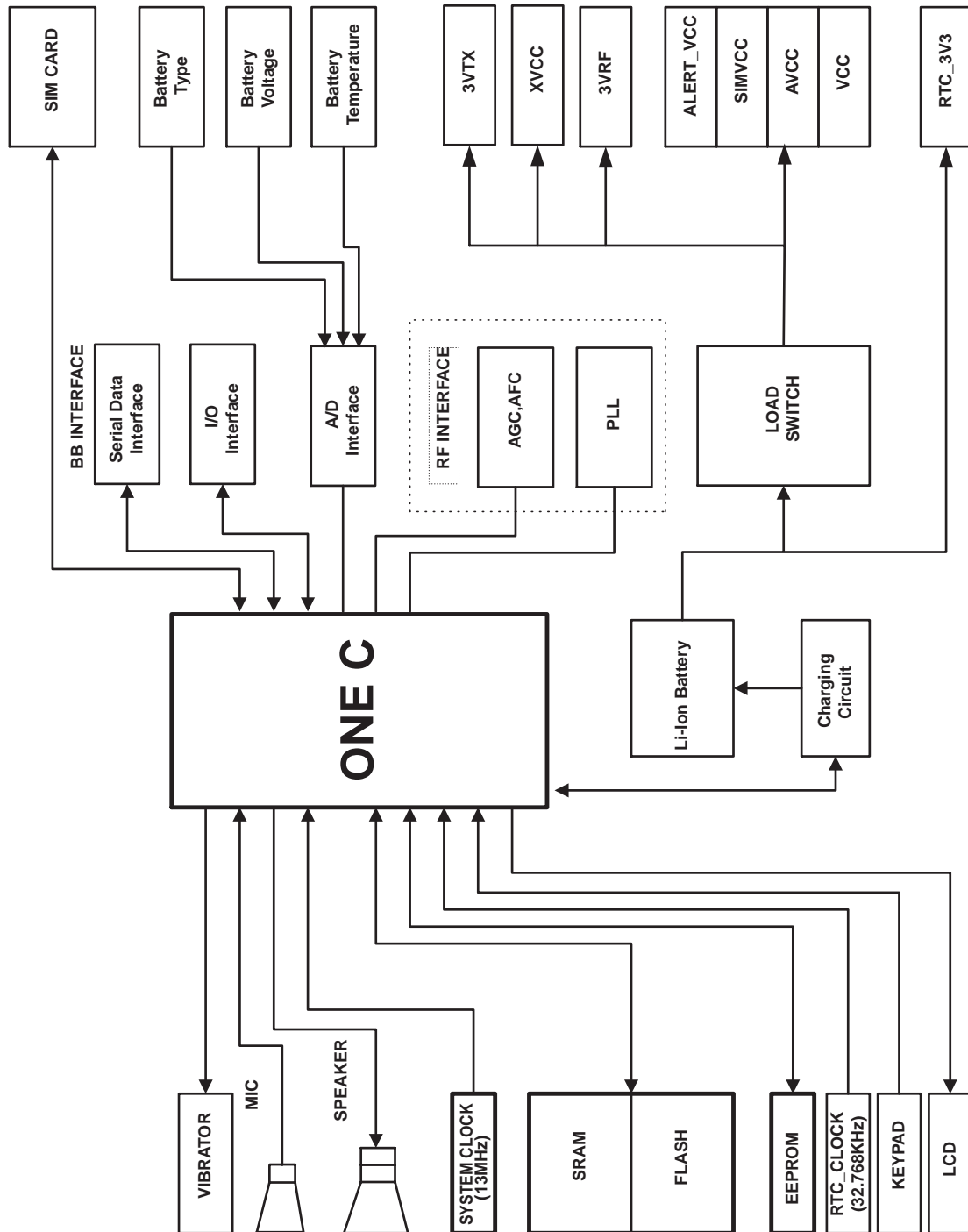

4-2 Main RF

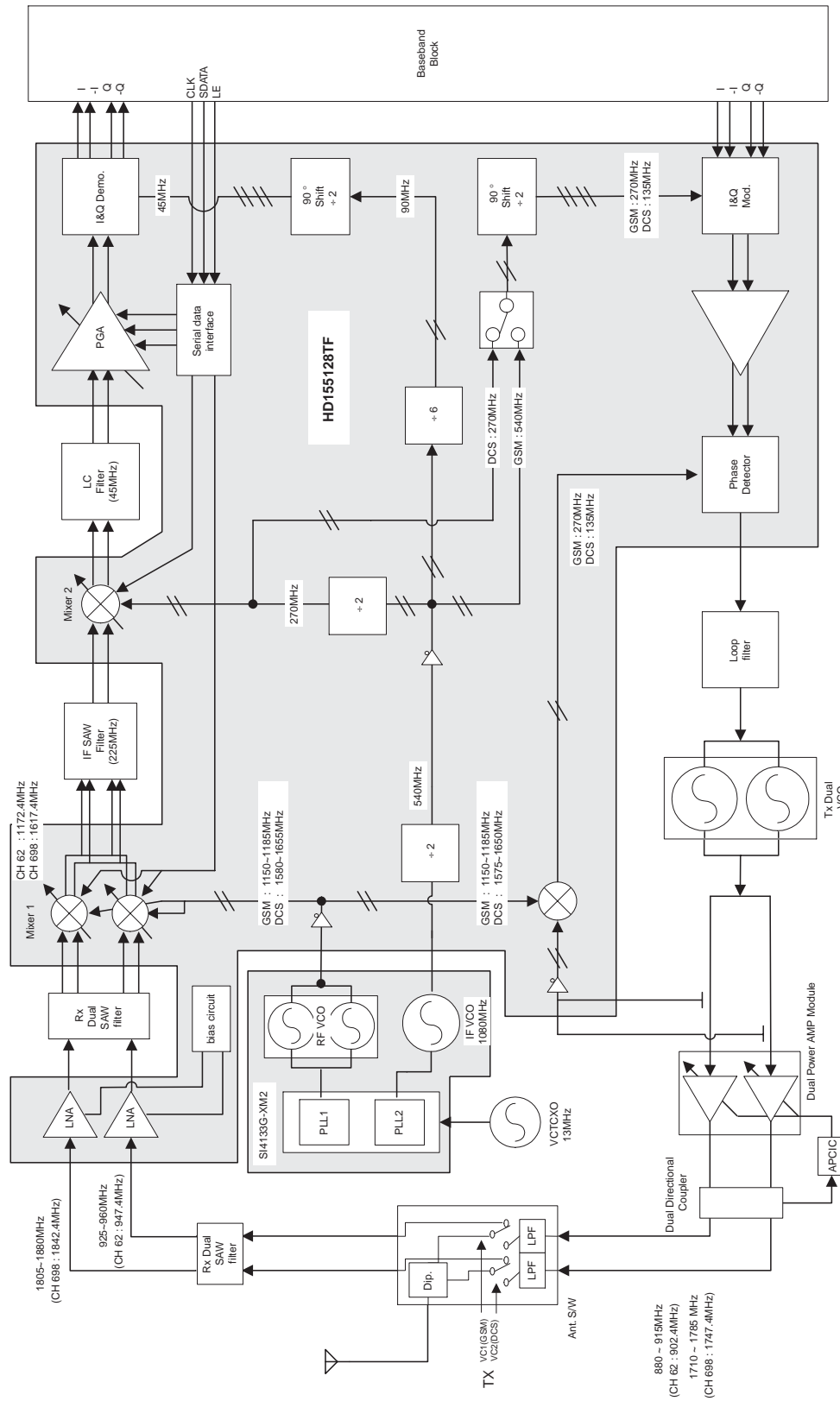

4-2-1 RF Transmit Part

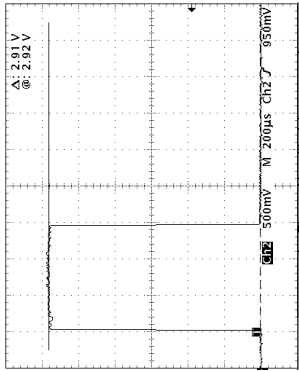

①

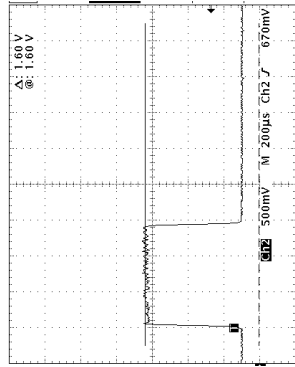

②

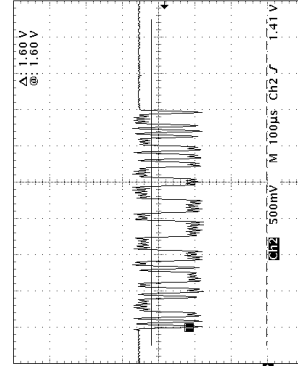

③

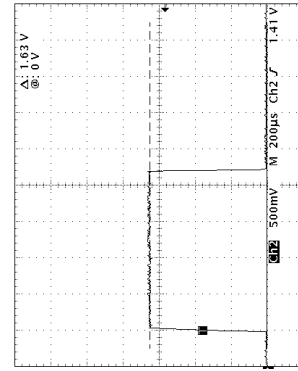
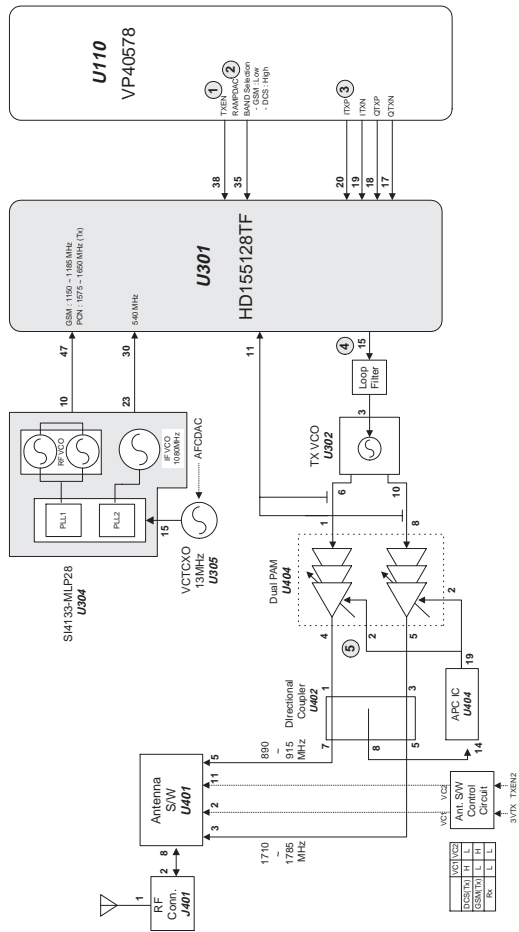

④

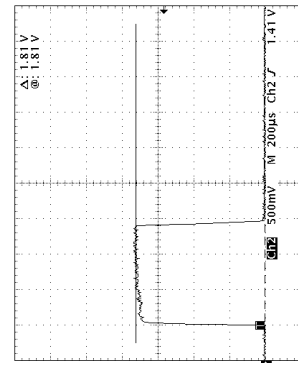

⑤

4-2-2 RF Receive Part

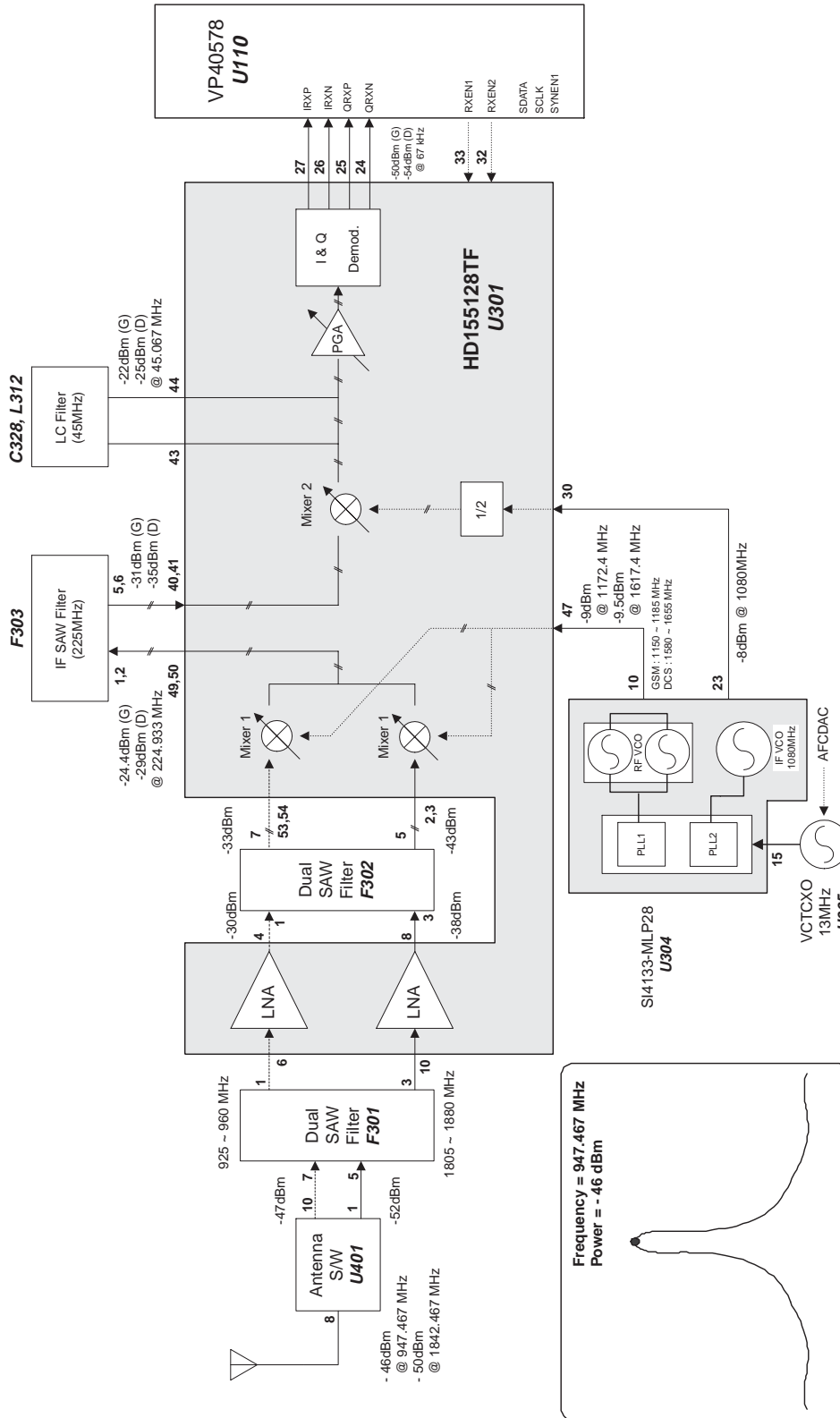

5. Flow Chart of Troubleshooting

5-1 Power ON

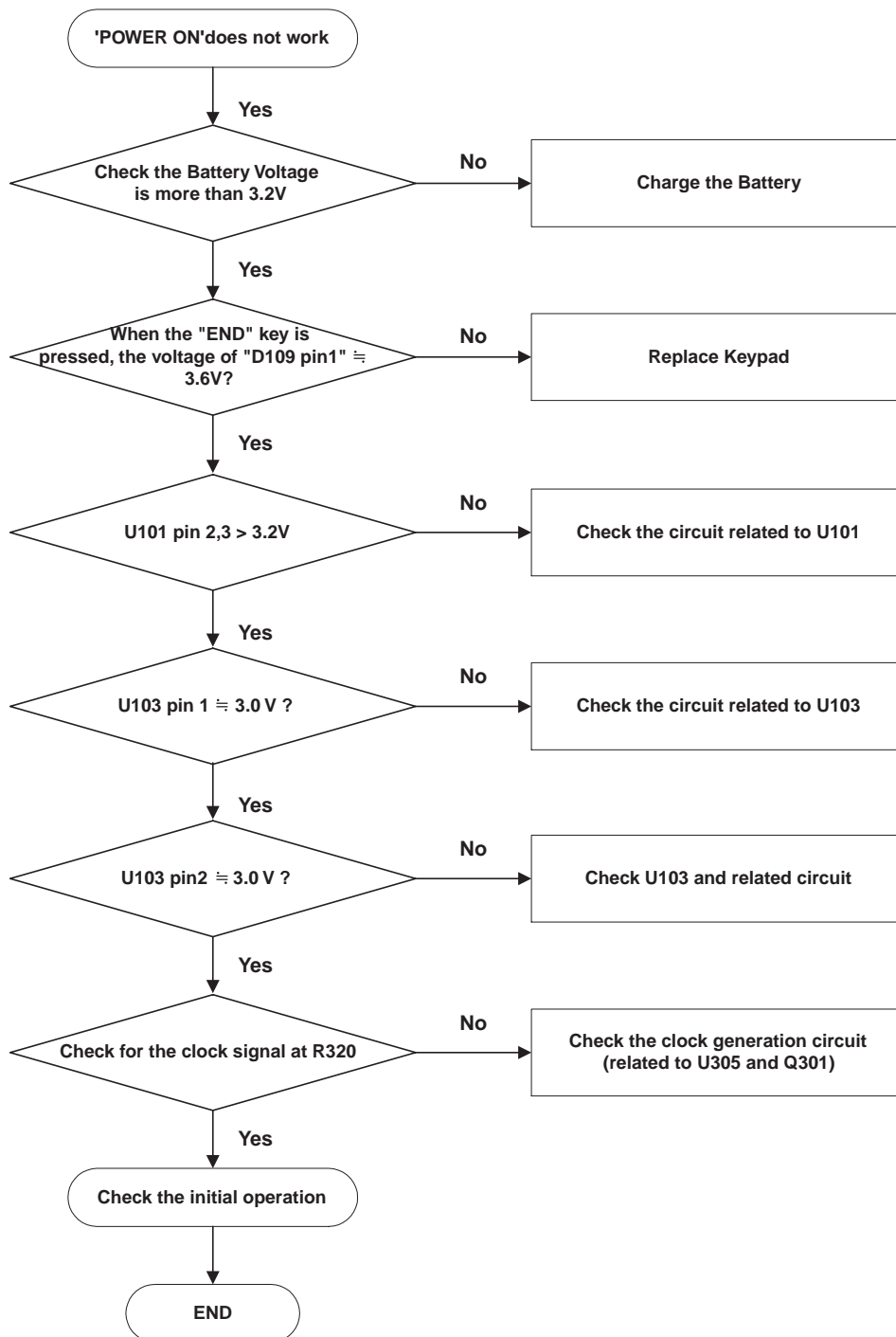

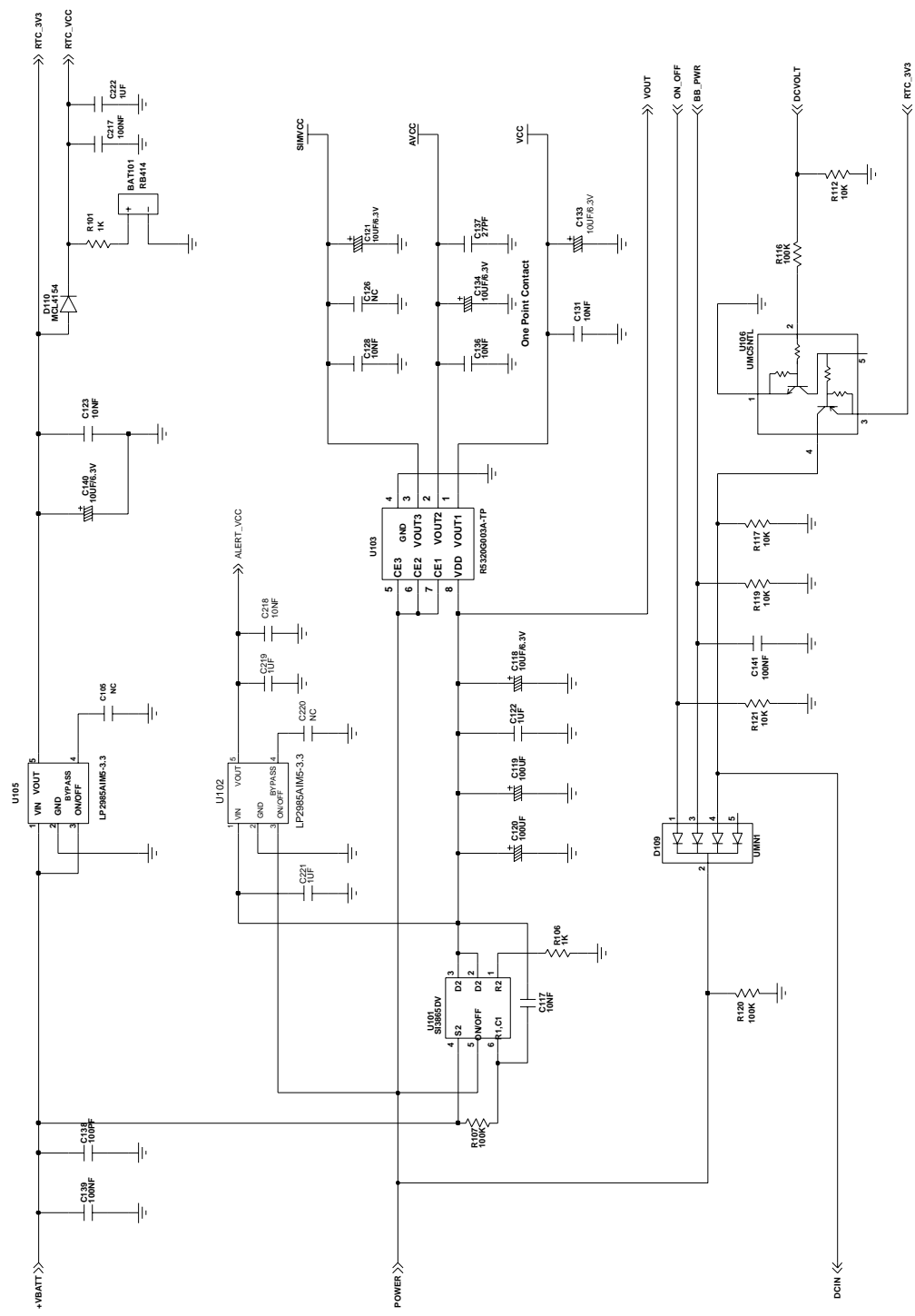

5-2 Initial

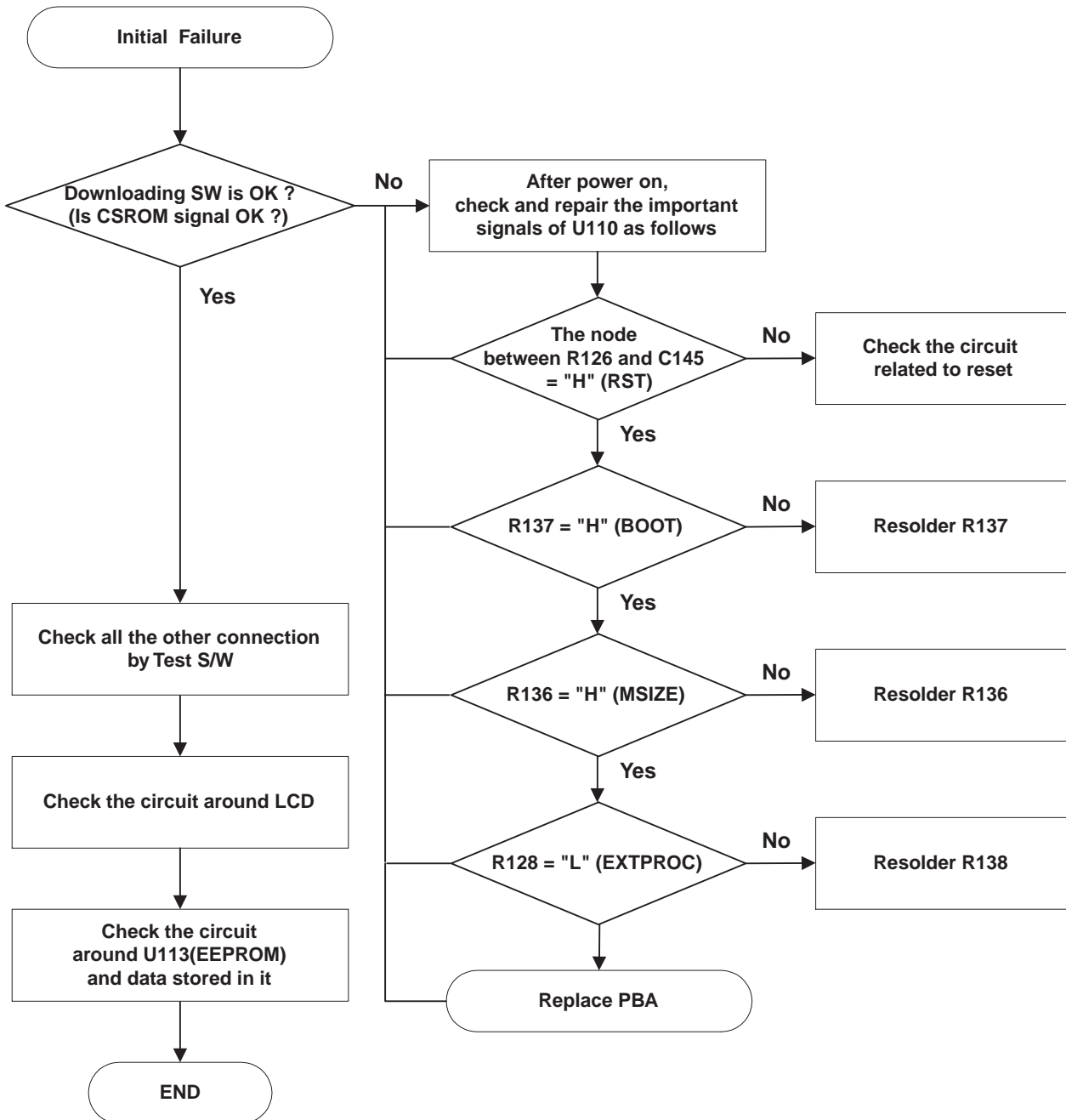

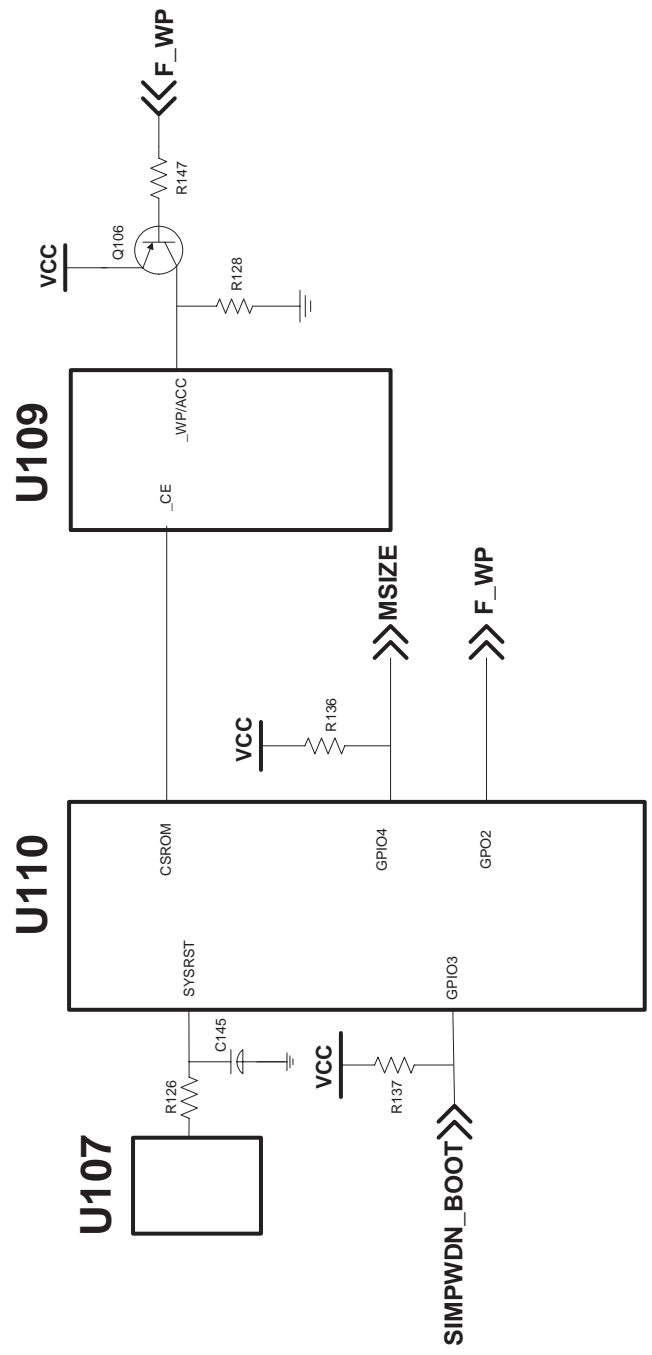

5-3 Charging Part

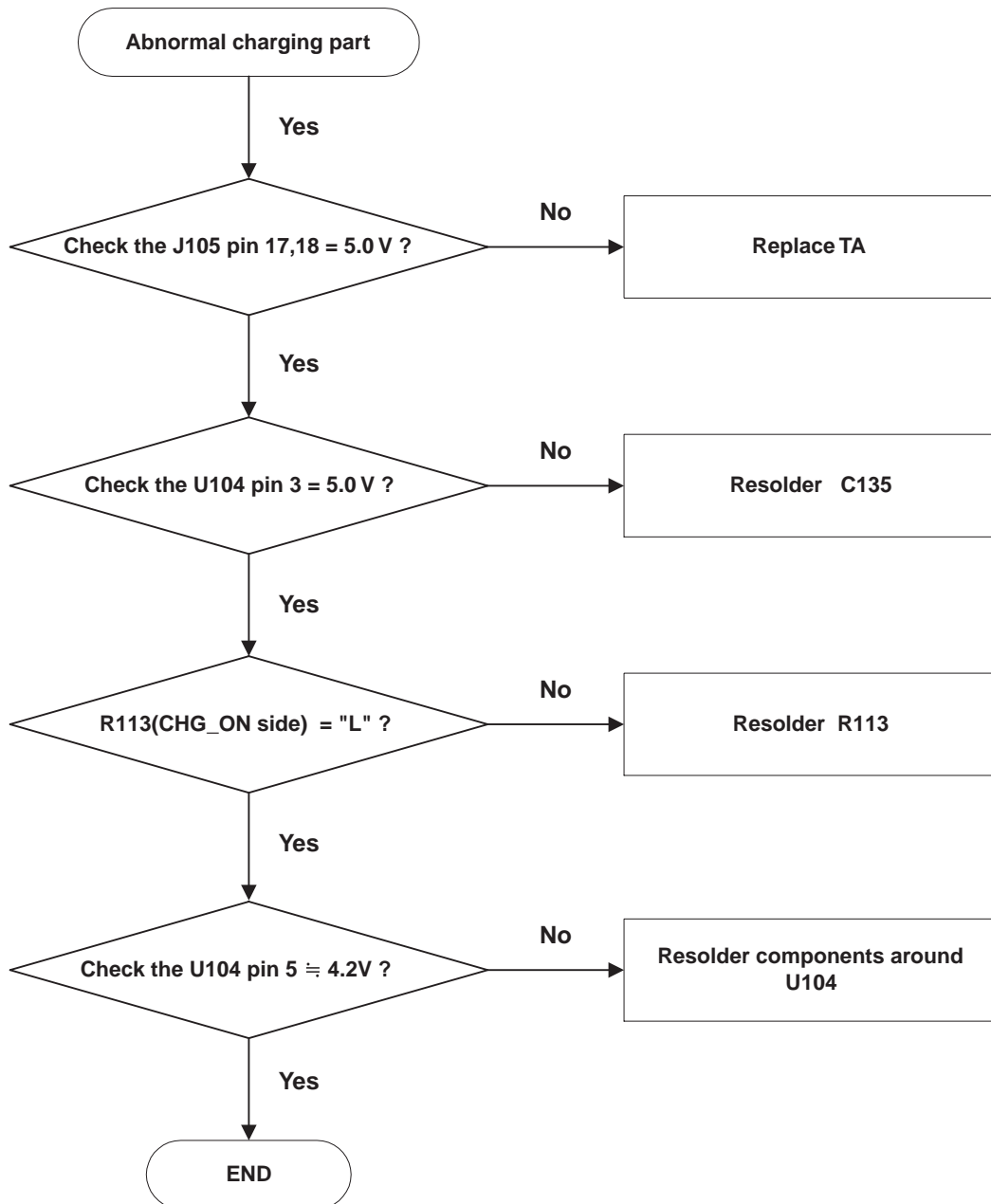

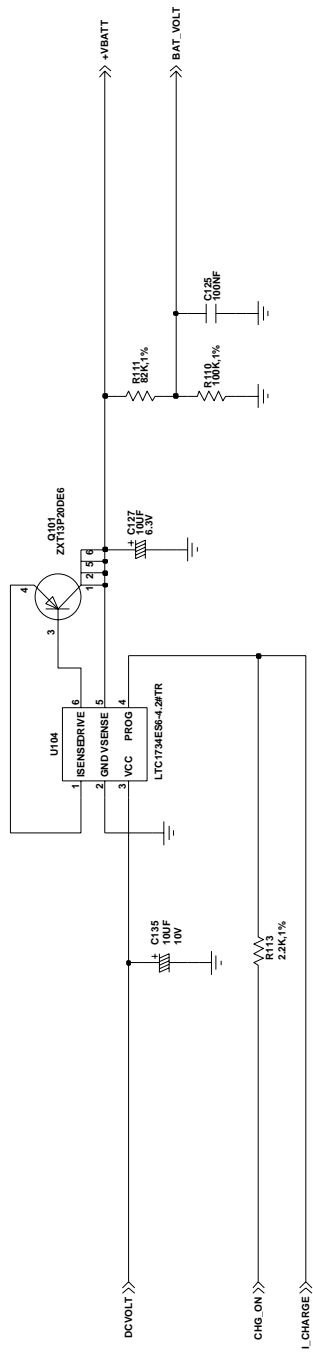

5-4 Sim Part

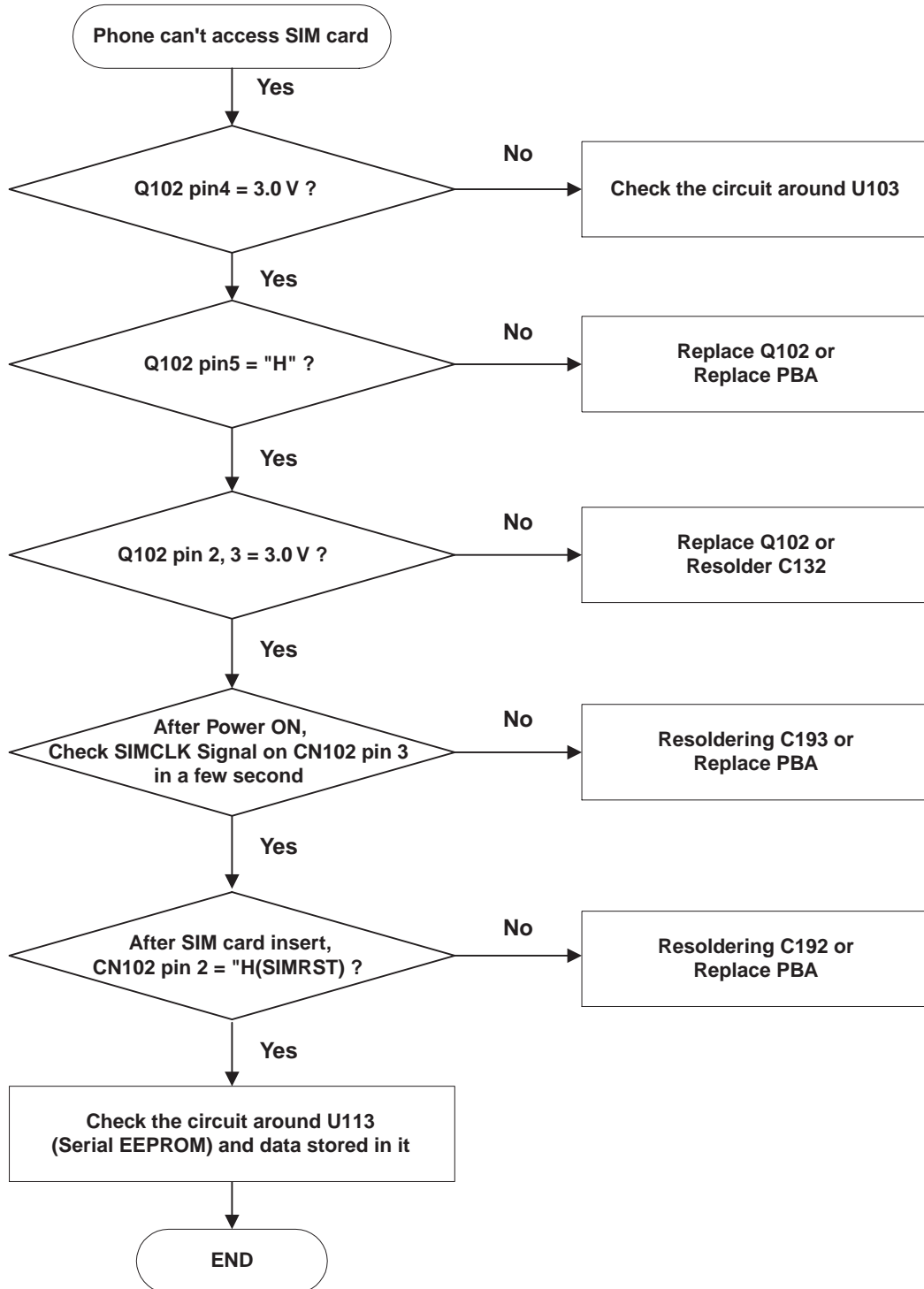

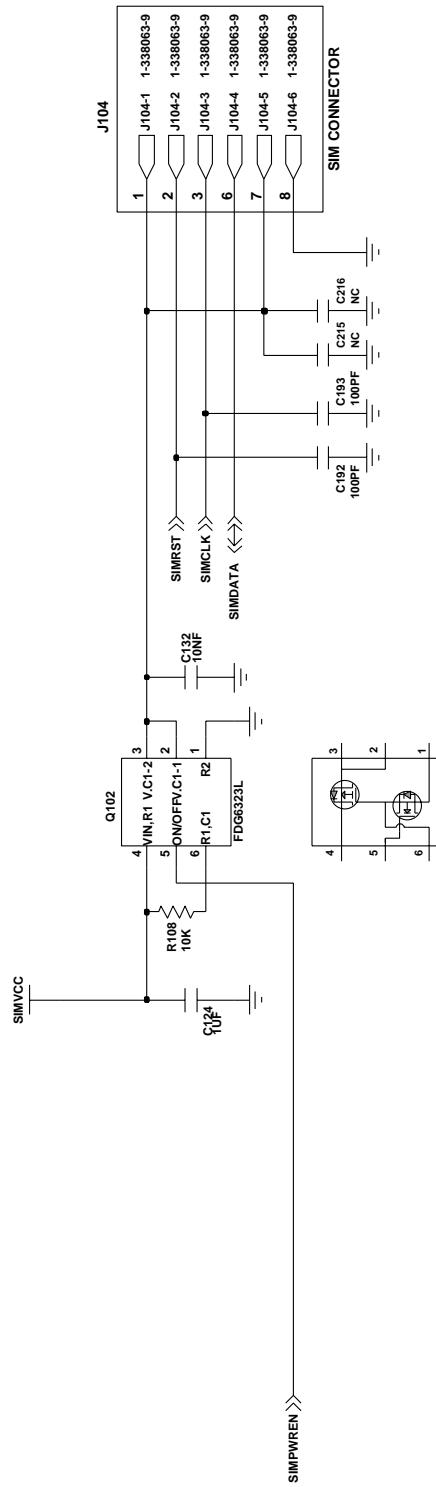

5-5 Microphone Part

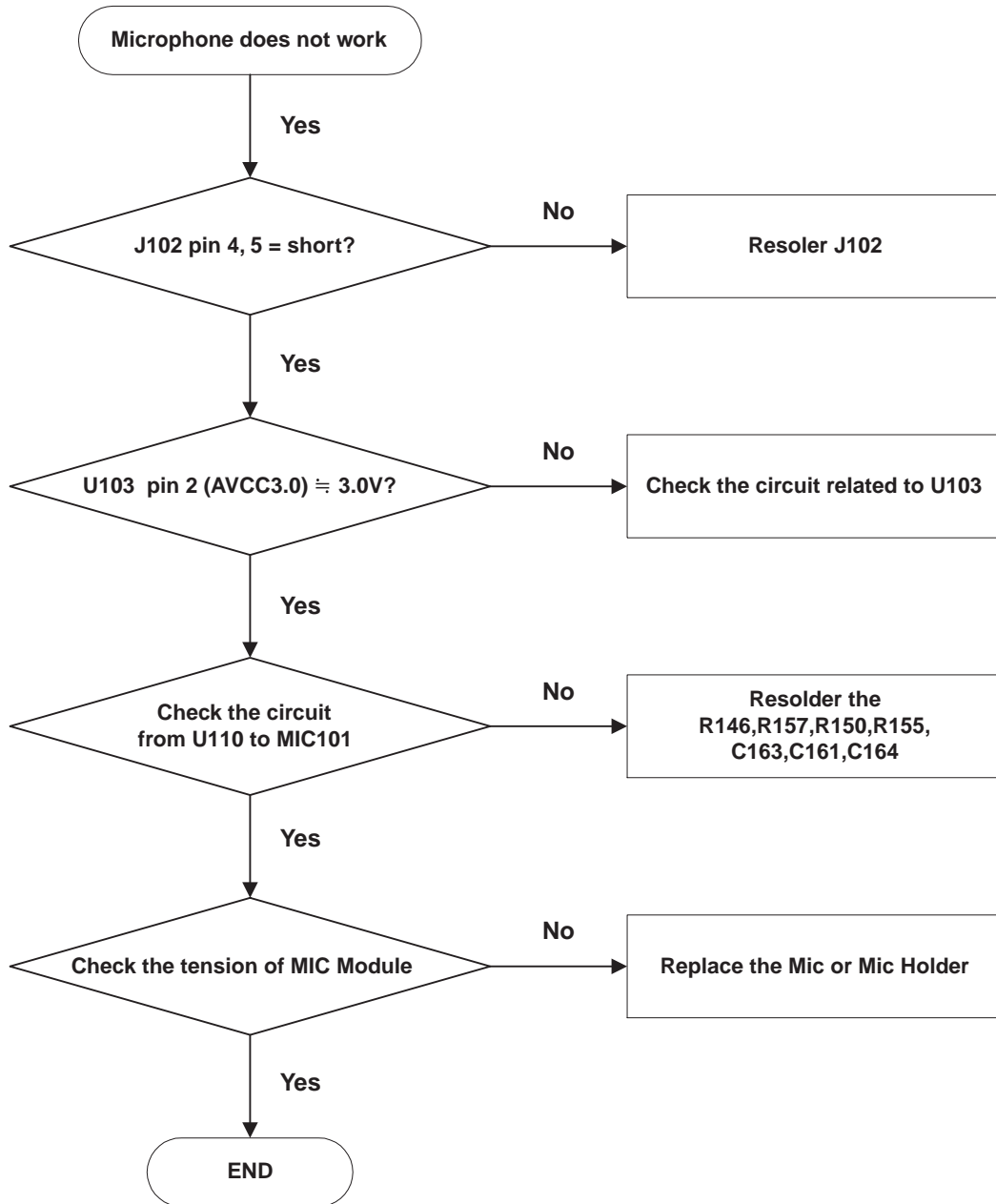

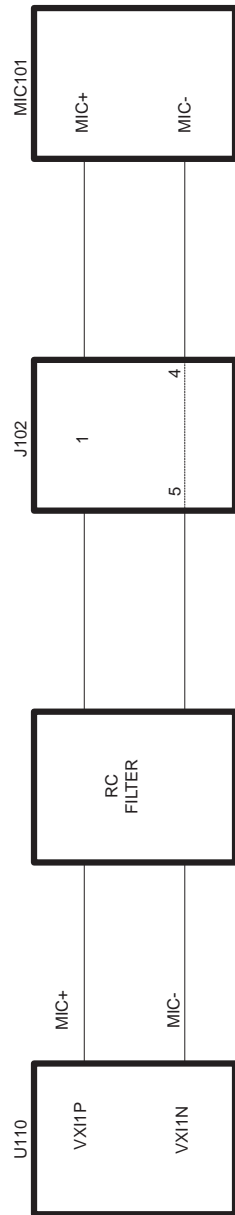

5-6 Speaker Part

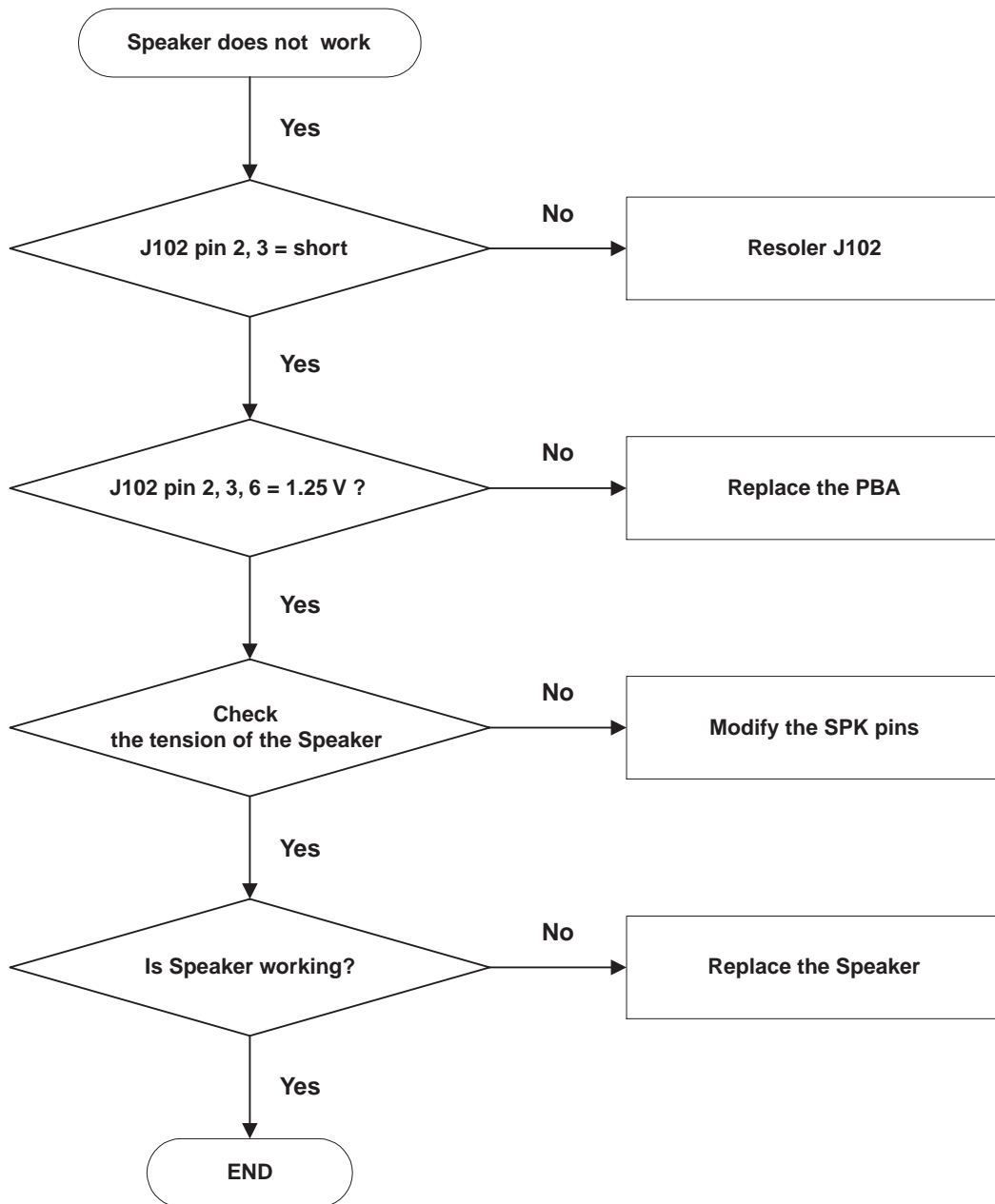

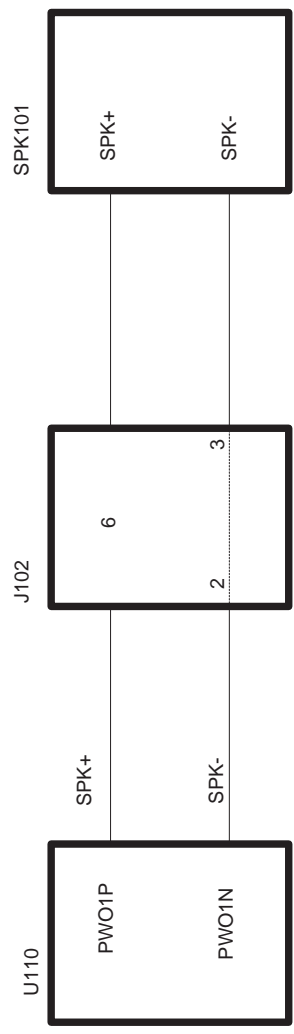

5-7 Key Data Input

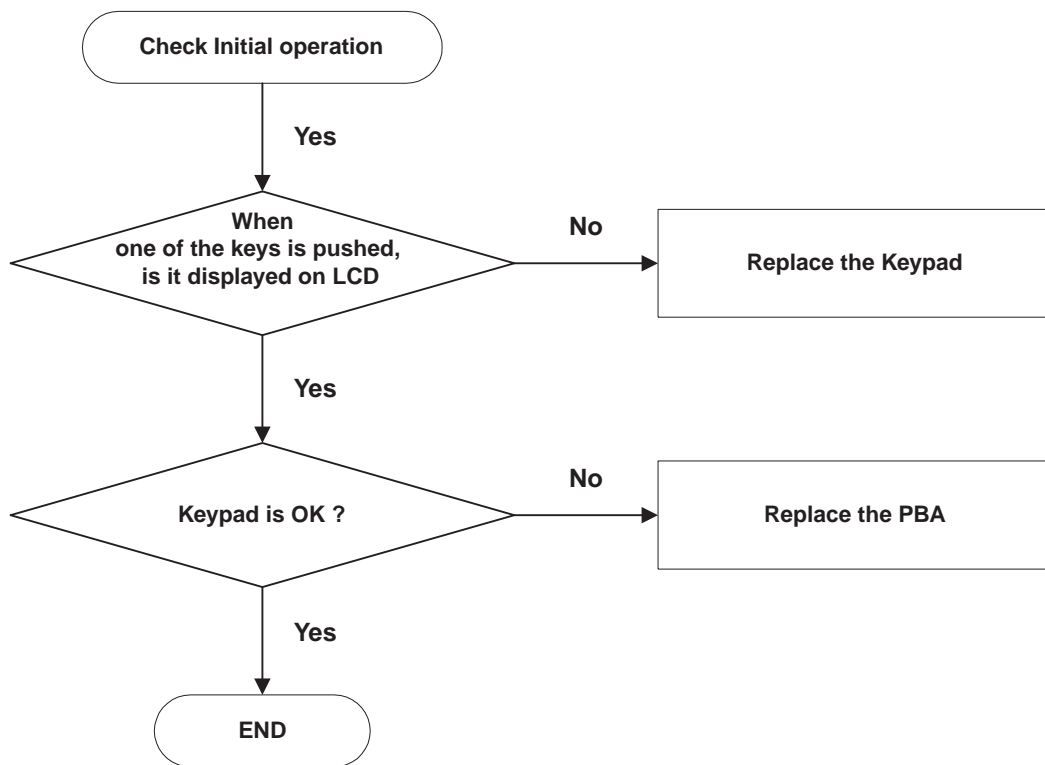

5-8 Alert Tone

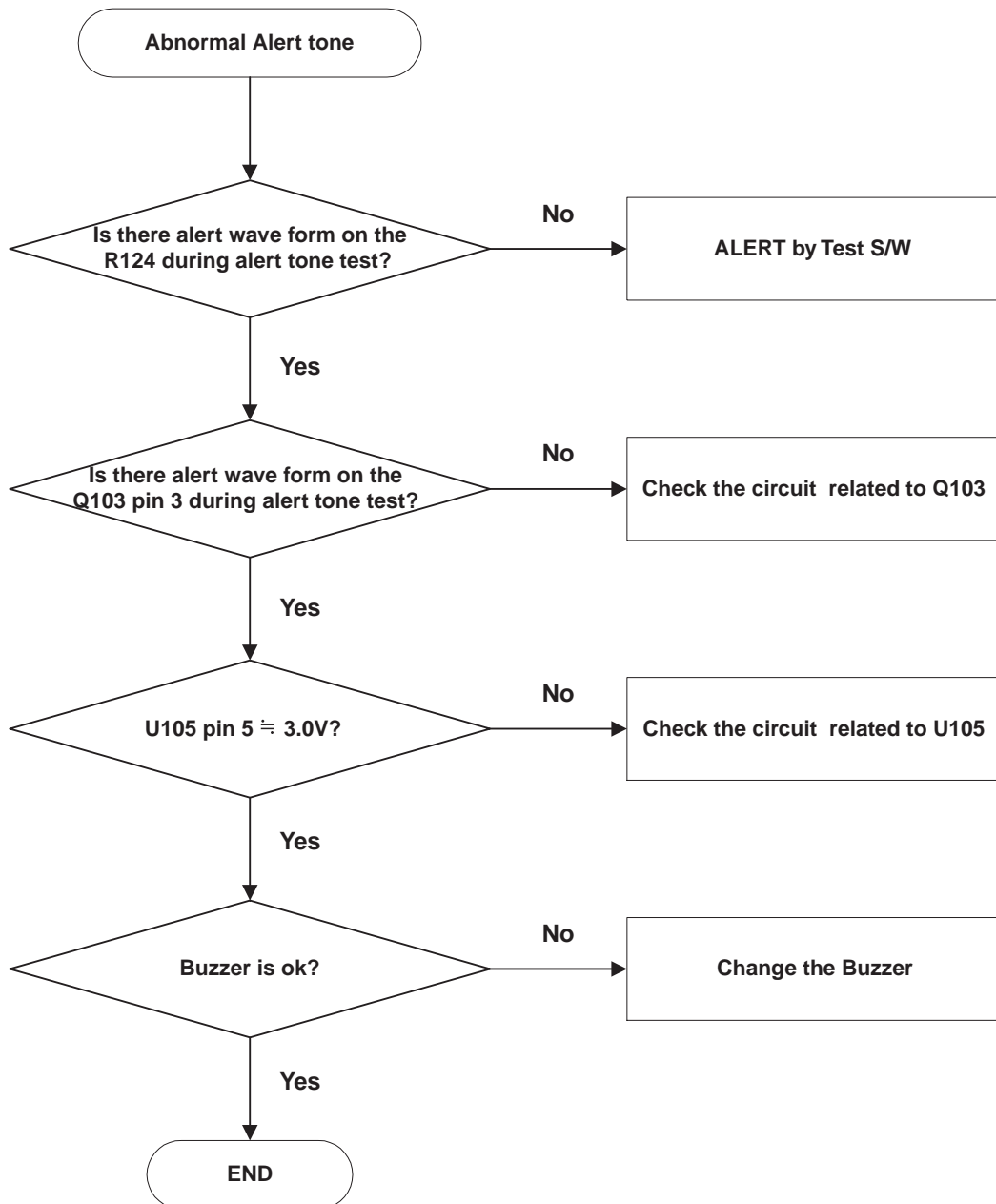

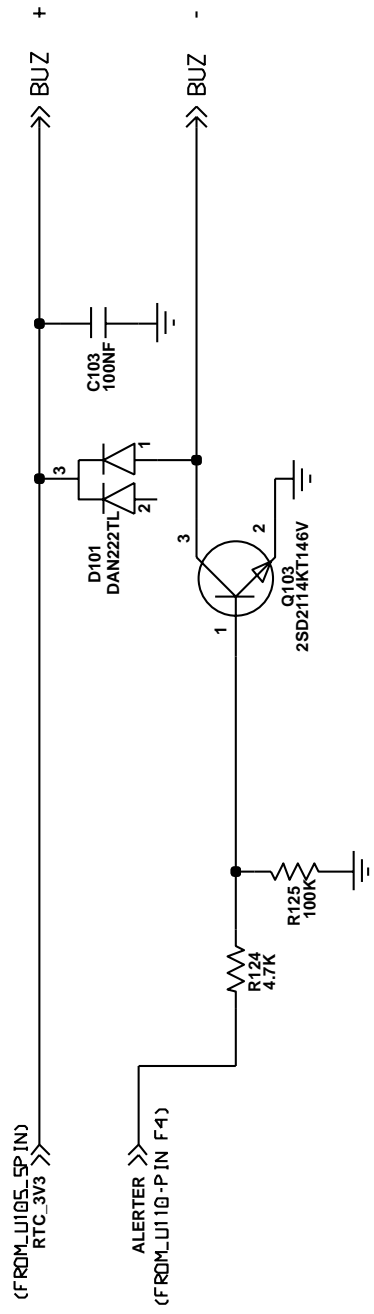

5-9 Ring Indicator

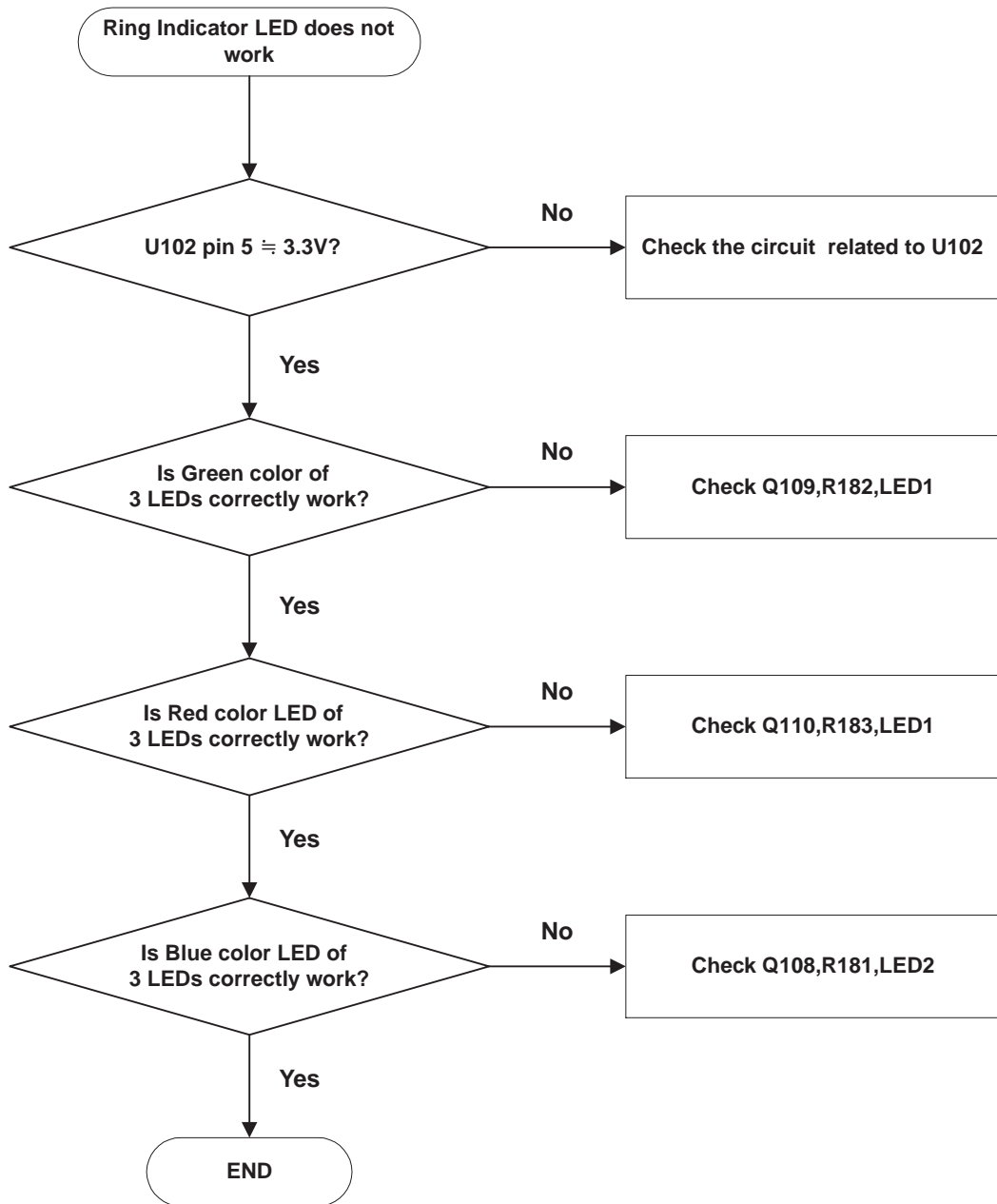

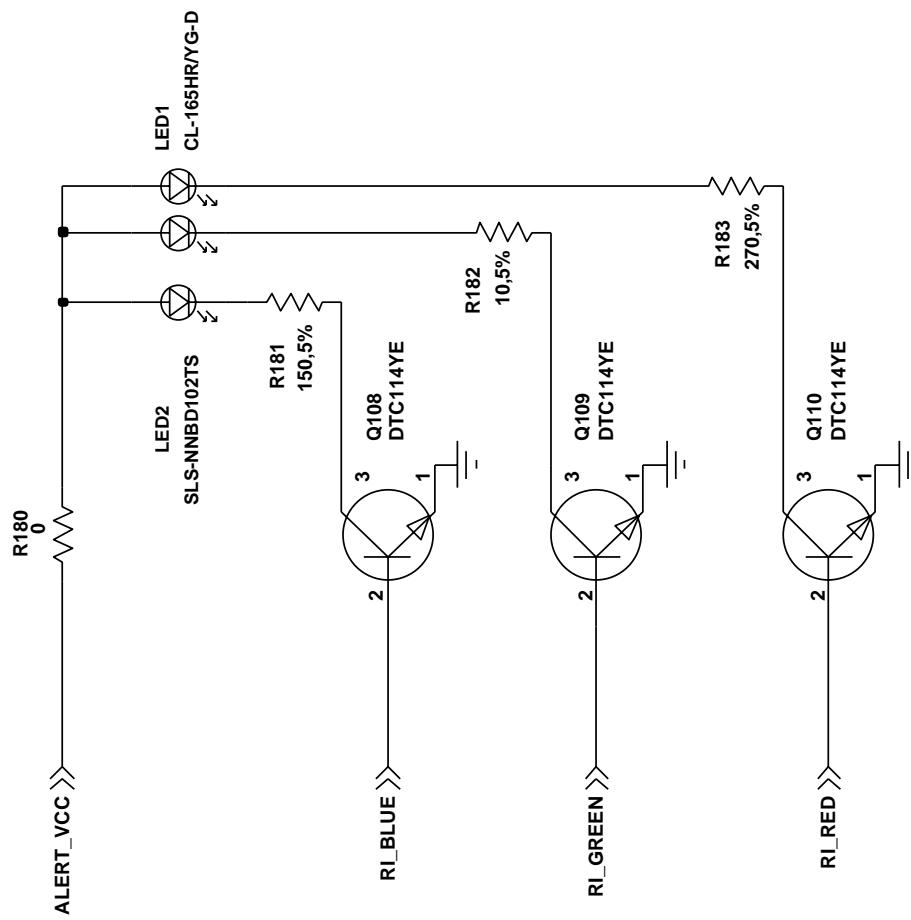

5-10 Back Light

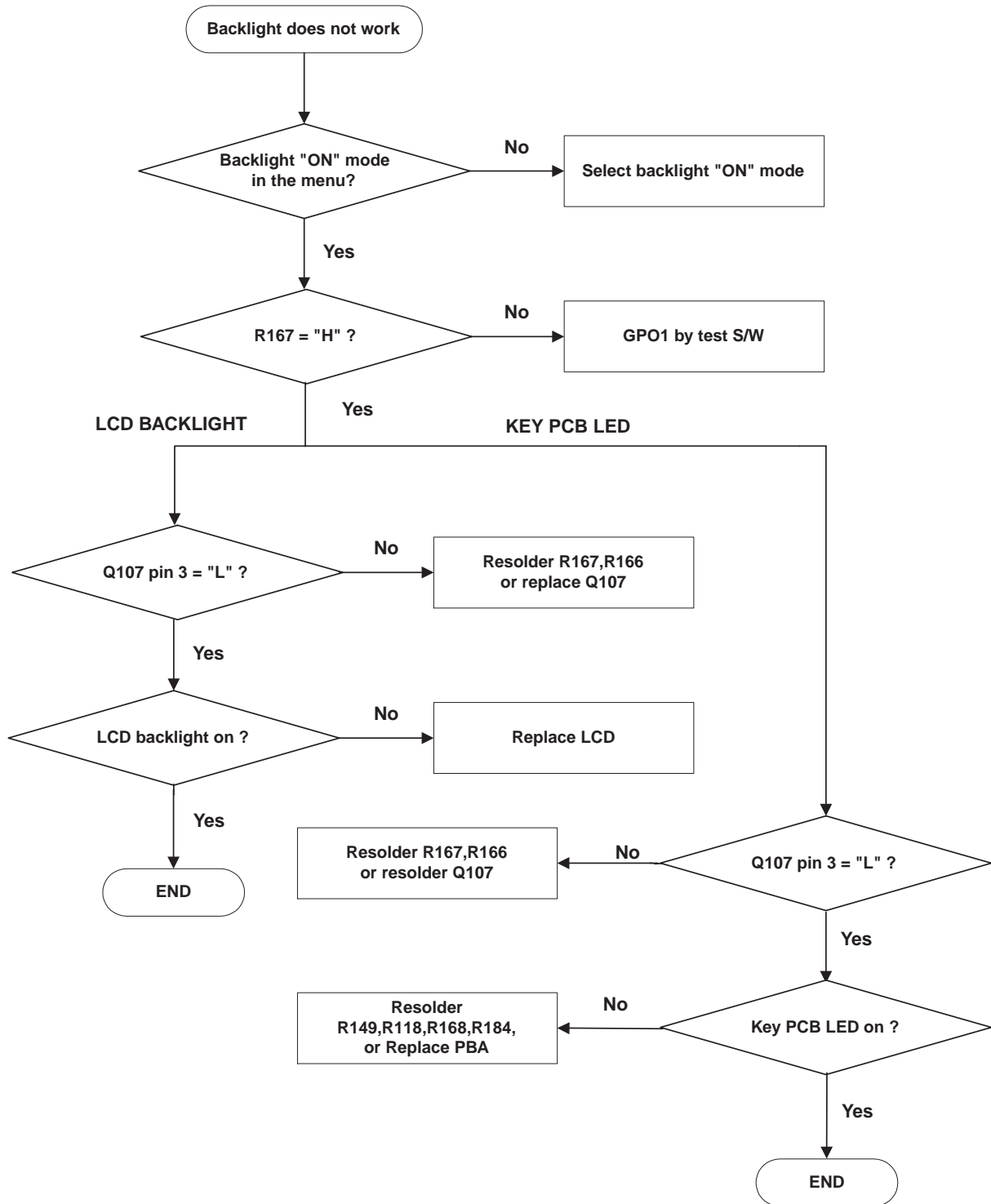

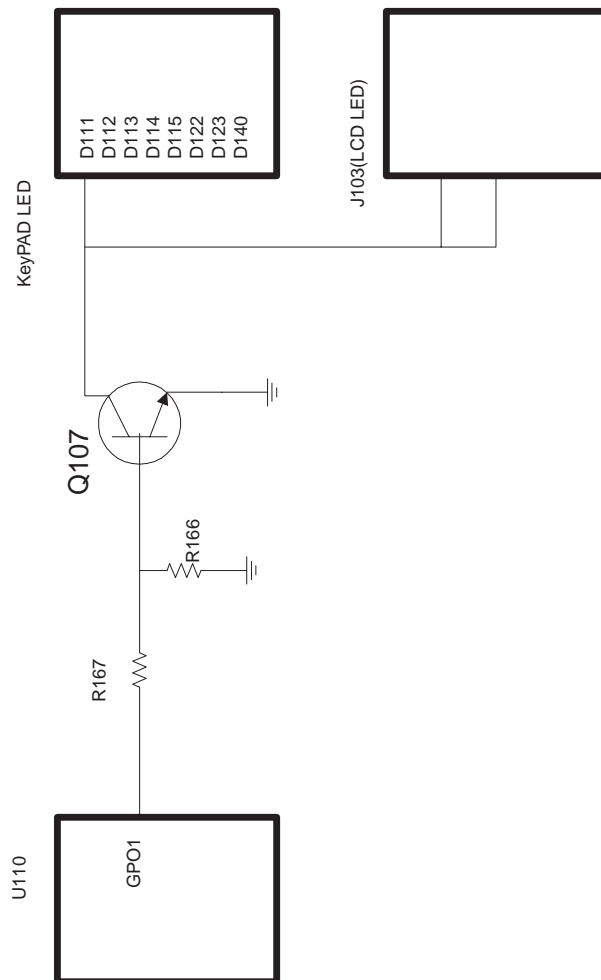

5-11 GSM Receiver

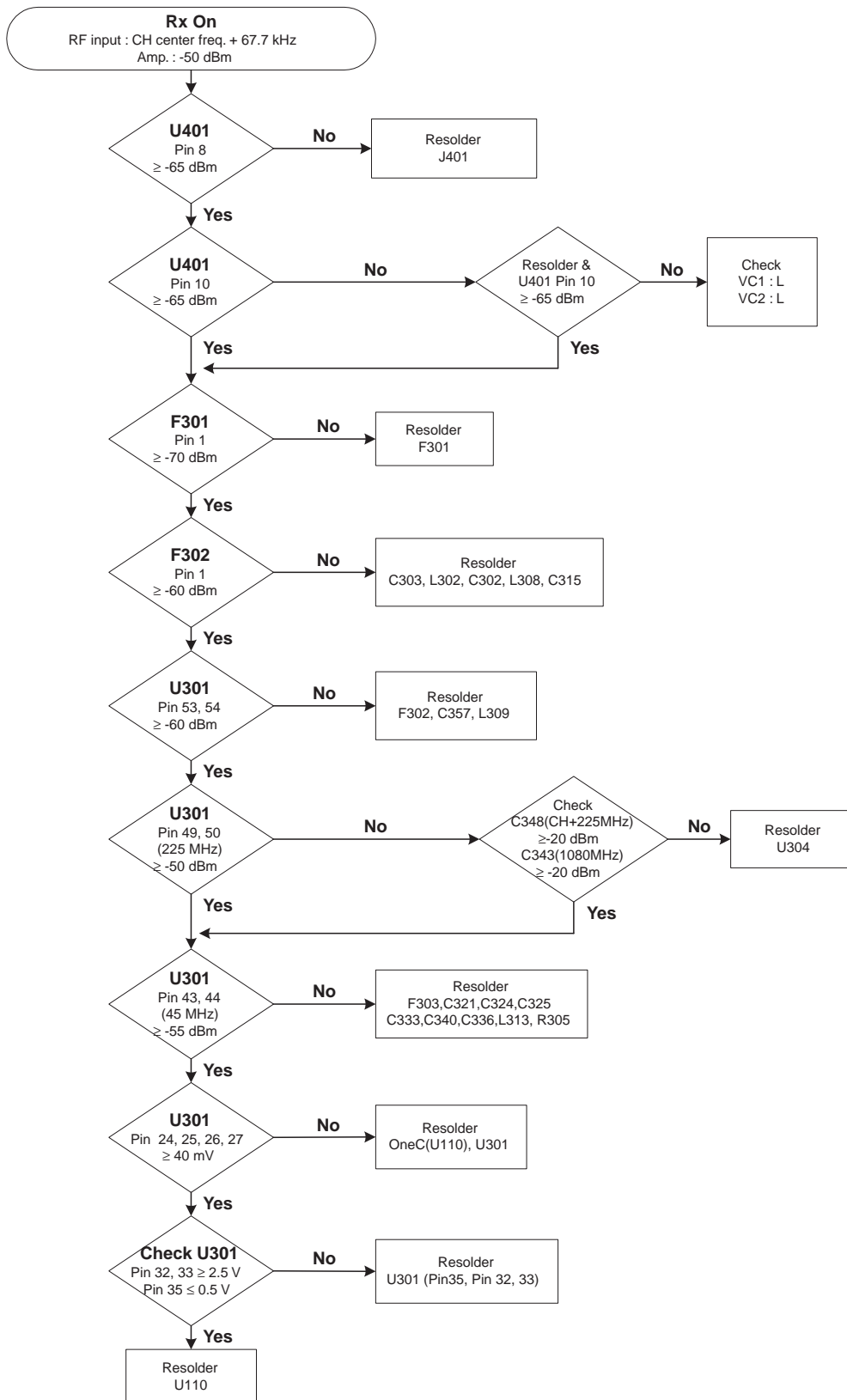

5-12 GSM Transmitter

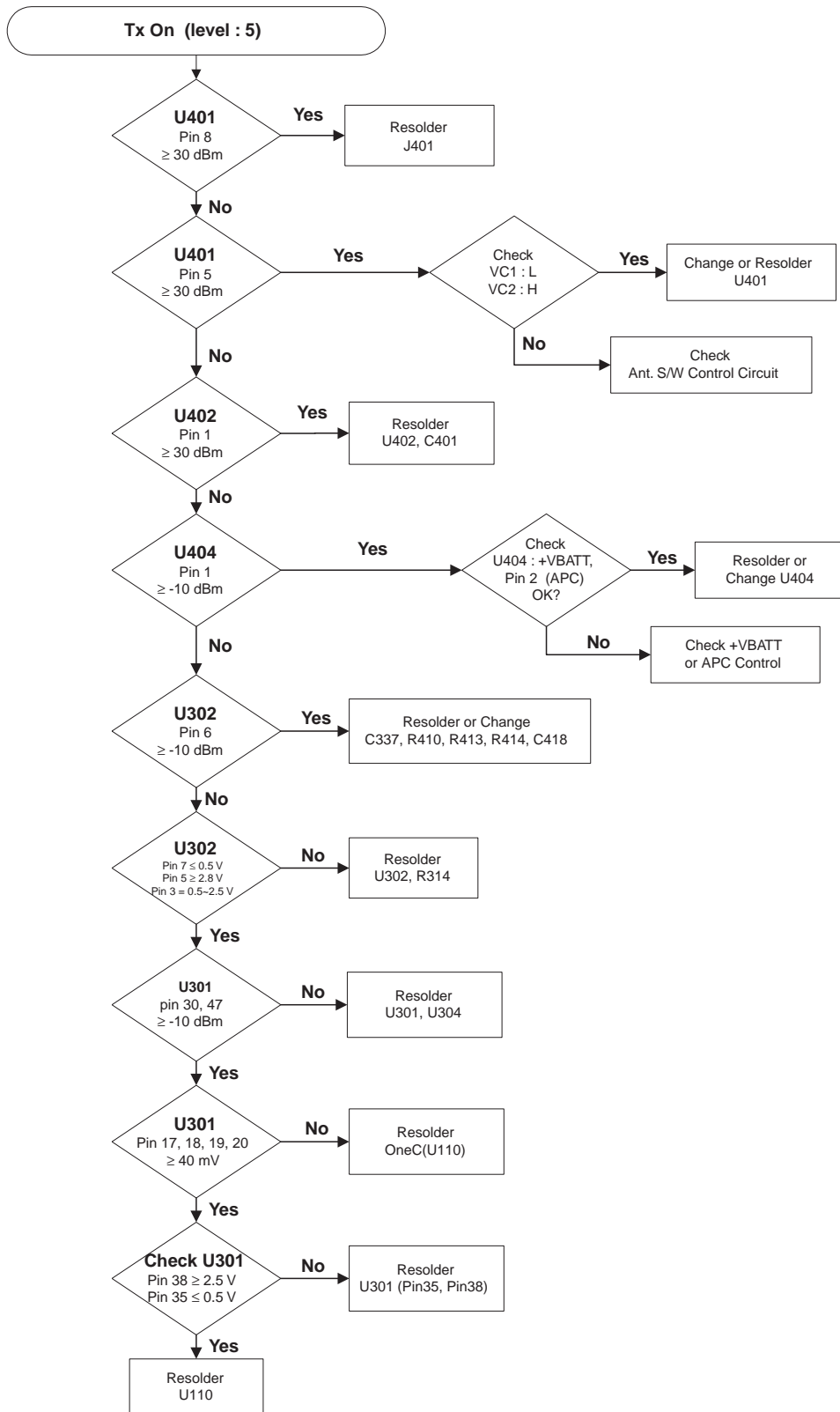

5-13 DCS Receiver

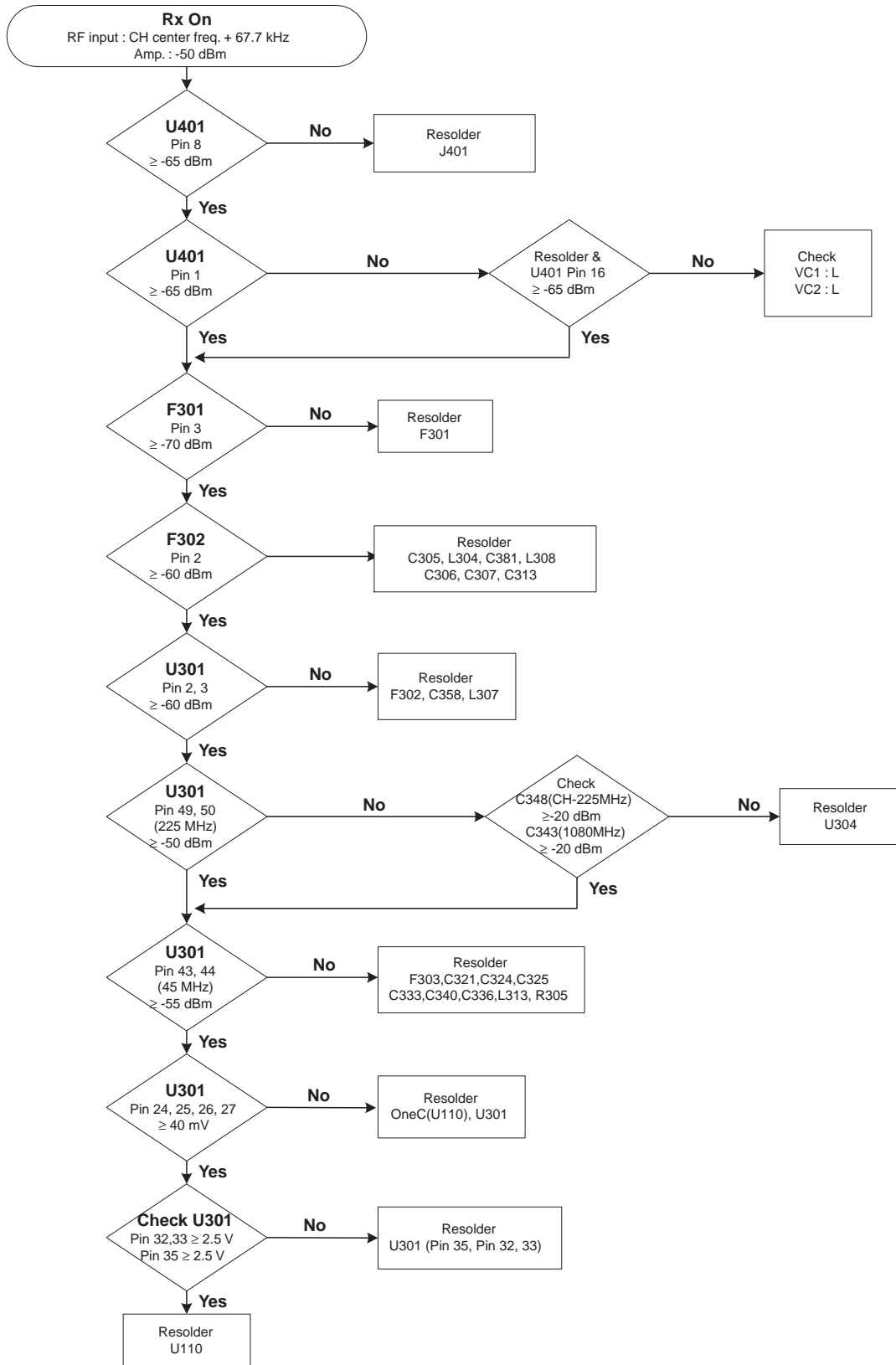

5-14 DCS Transmitter

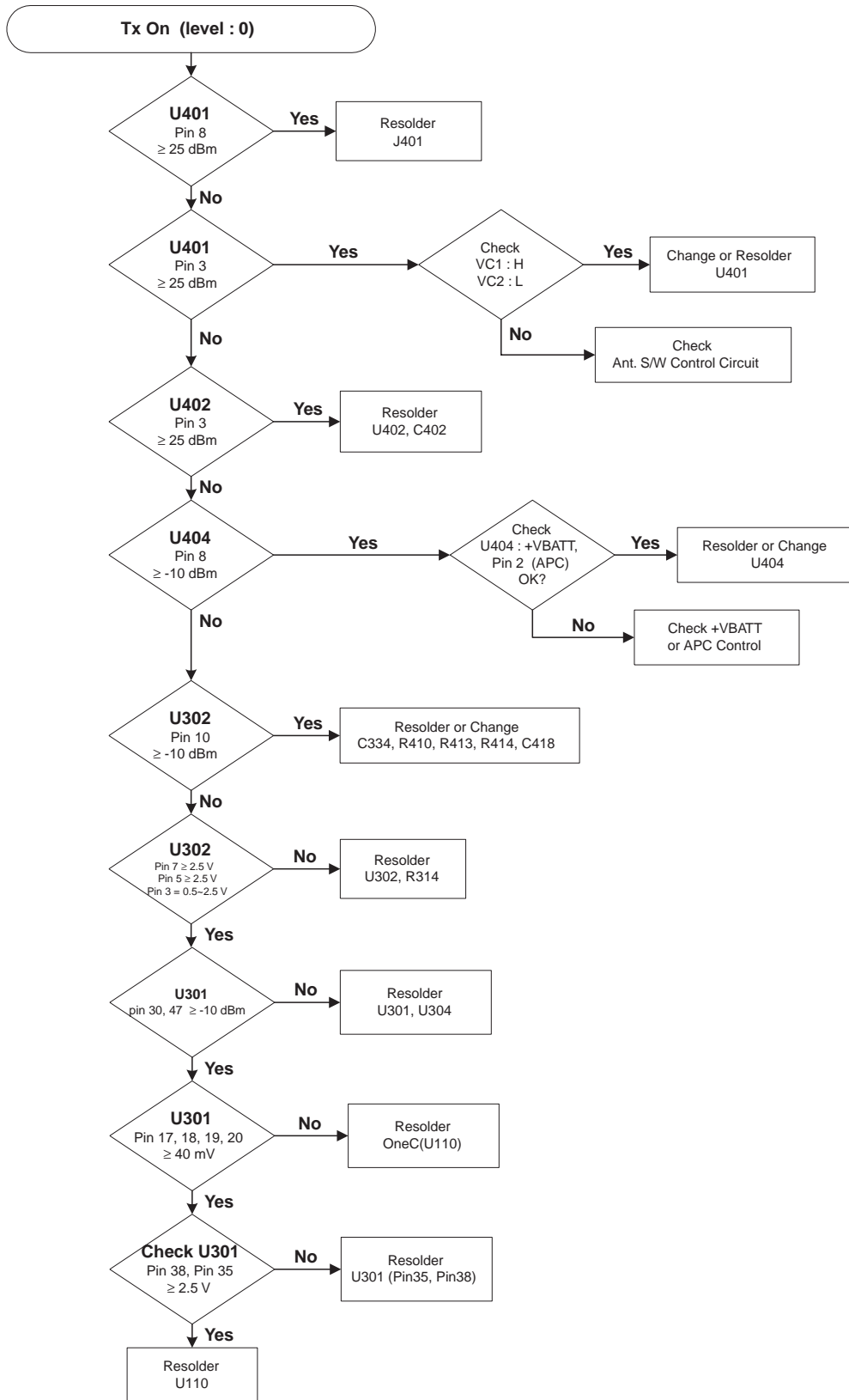

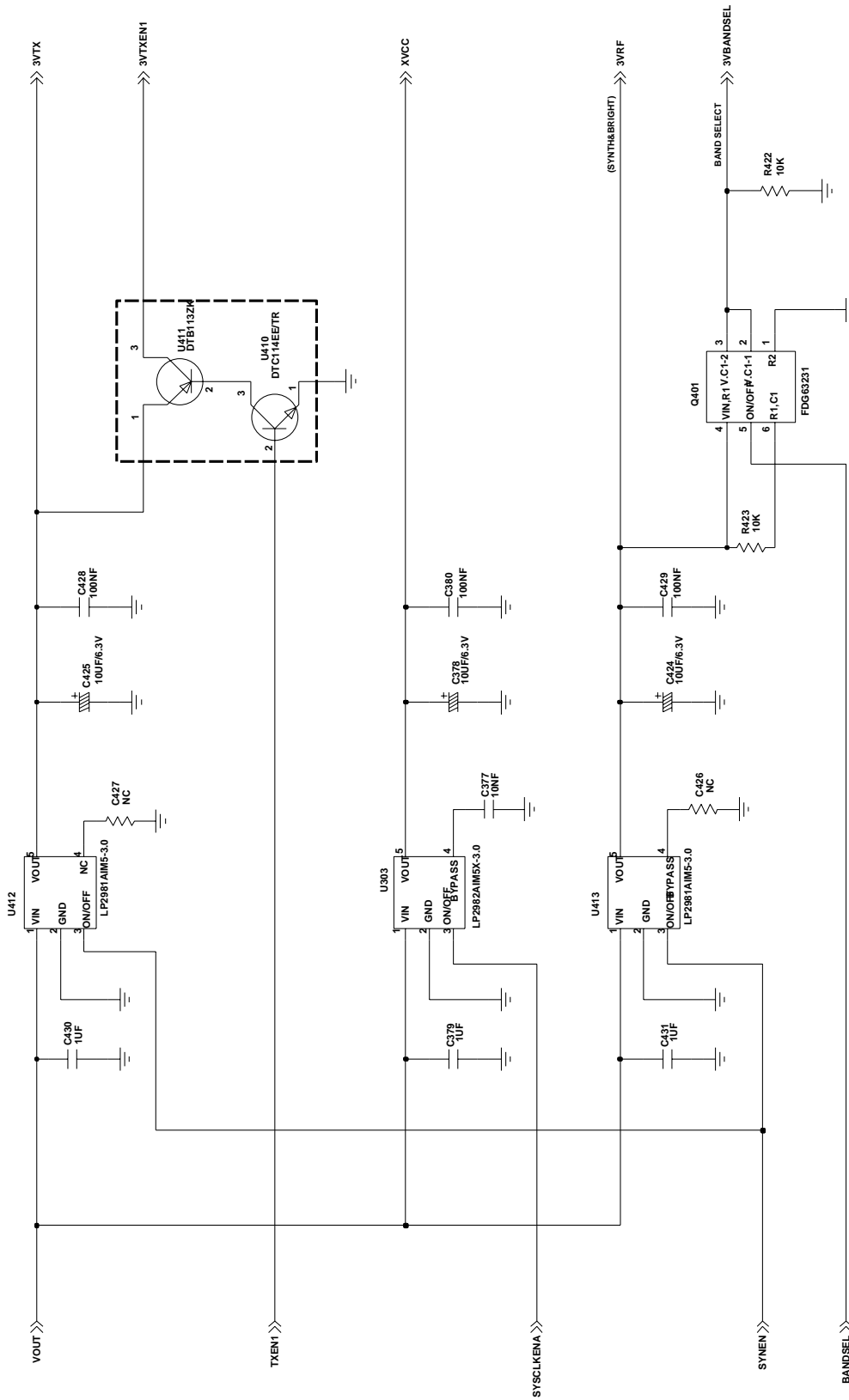

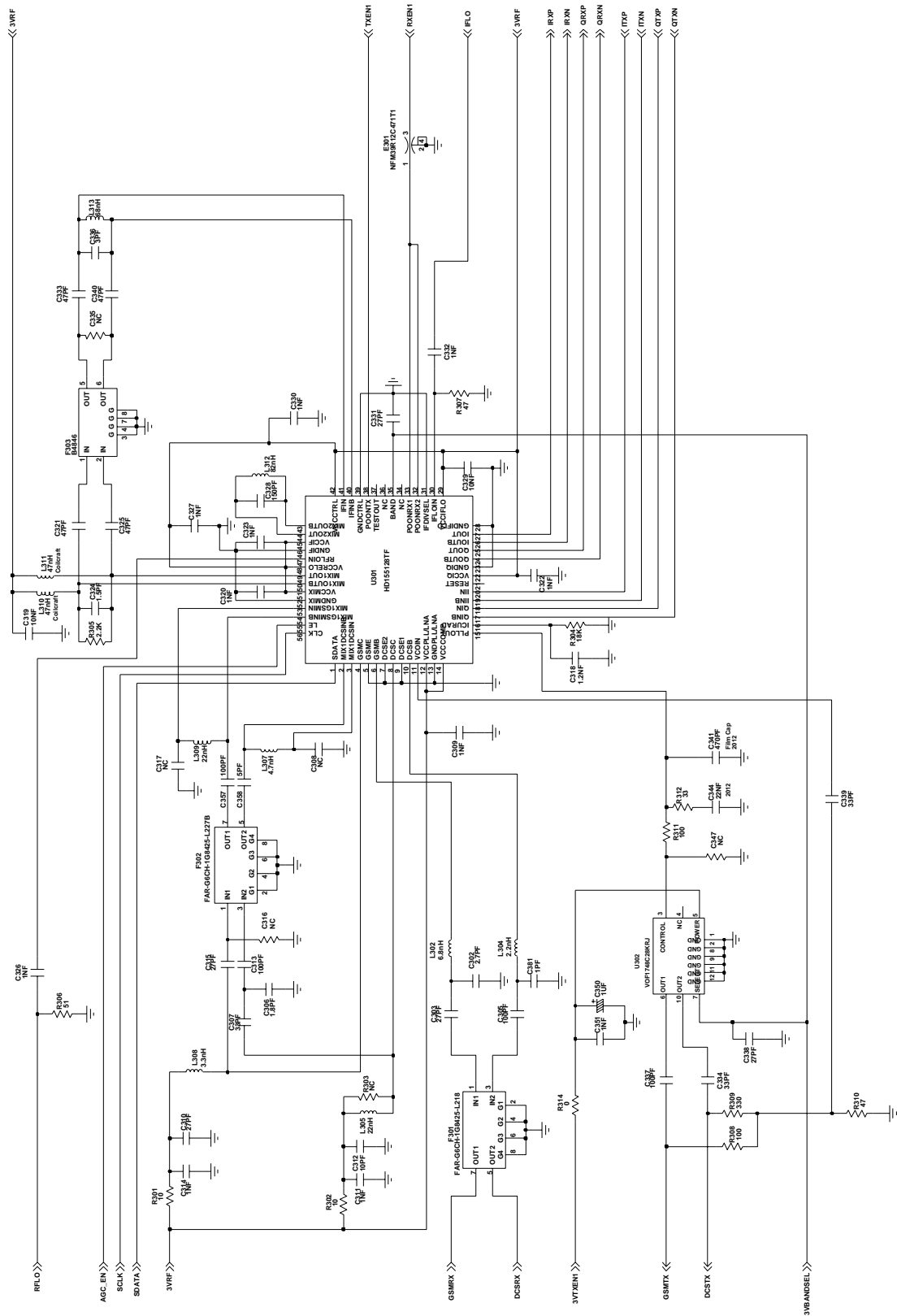

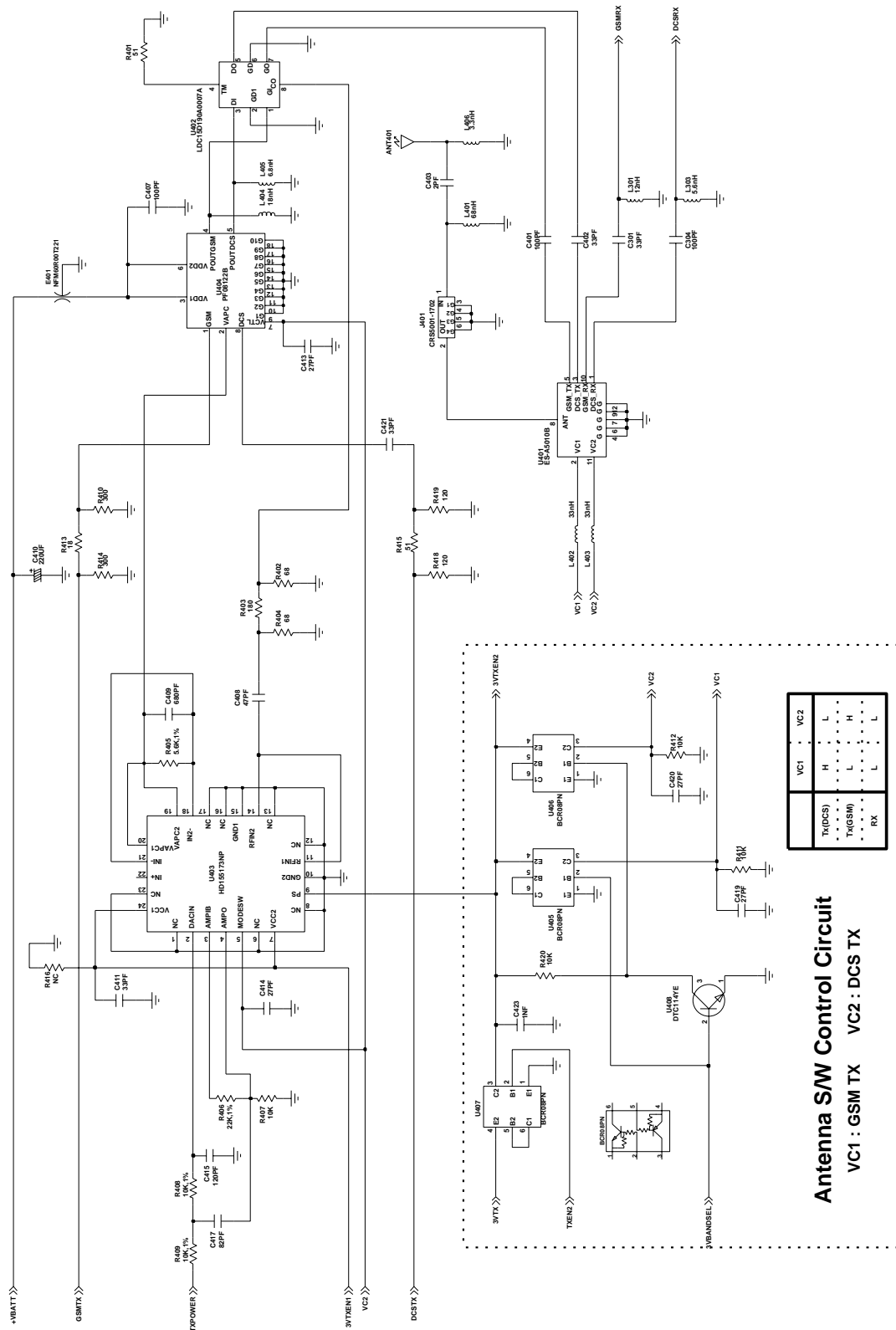

Antenna S/W Control Circuit
 VC1 : GSM TX VC2 : DCS TX